

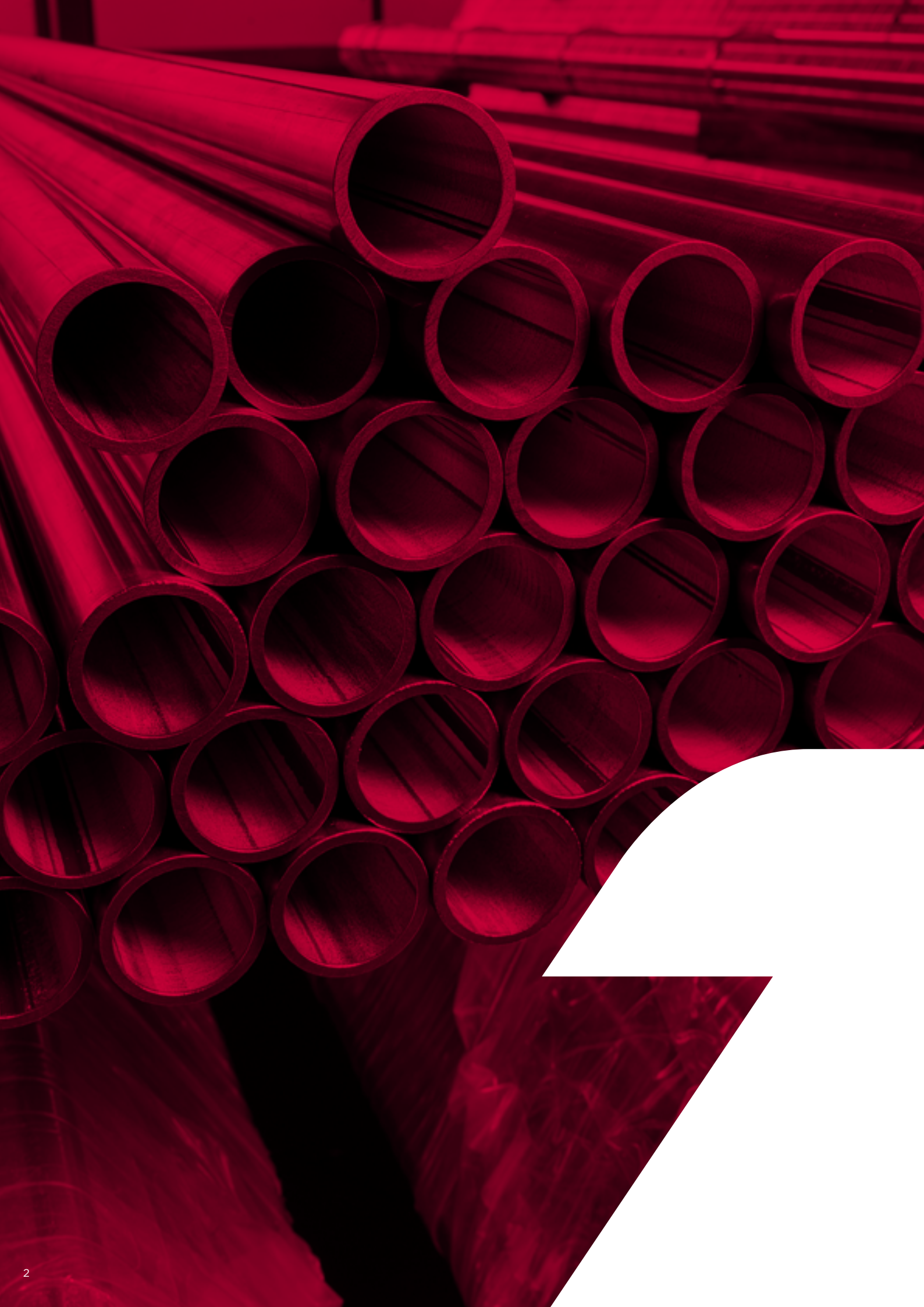

integrated  
piping systems

## VSH PowerPress®





# contents

Aalberts Integrated Piping Systems	4
VSH	6
VSH PowerPress®	8
<b>technical data</b>	<b>11</b>
applications	12
fittings	13
tubes	14
press tools	16
installation guidelines	17
general installation information	19
built-in	20
corrosion	22
<b>product range</b>	<b>25</b>
fittings	25
valves	33
tools and accessories	59



# don't just buy products, buy solutions.

Aalberts Integrated Piping Systems



Aalberts Integrated Piping Systems develops and produces connectors, metal and plastic tubes, valves, and fastening technology for the distribution and control of liquids and gases. Our technologies enable customers to work quickly and reliably in a simple and efficient way.

**integrated piping systems**

These bespoke systems are applicable for key vertical markets such as residential, commercial, industrial and utility. Our complete range of integrated piping systems and fittings is always available through a wide range of various distribution channels. Furthermore, our own engineers are always developing our existing systems and services to the next level, as well as the design of completely new and innovative solutions.

**This is how Aalberts Integrated Piping Systems enables its customers to make every project a success.**

**global footprint with a local presence**

We are part of Aalberts, a globally operating technology group and currently active at 30 locations in 14 countries, offering the broadest and most advanced portfolio. At Aalberts Integrated Piping Systems, we combine an overall technical expertise, global knowledge exchange, and the continuous drive to innovate within our group, with our knowledge of local markets and involvement in our customers' business. We offer them

advice, Design Service and complete customised solutions from the design phase right through to delivery and aftercare, via our Aalberts Integrated Piping Systems Design Service®.

**We take away all our customers worries and concerns and offer them a complete integrated piping solution, each and every time.**

**exceeding expectations**

At Aalberts Integrated Piping Systems we not only invest in our customers, but also in our own employees. Because we realise that they are the heart of our company. With passion, teamwork, ownership and diversity, we have the ability to think 'out-of-the-box'. This means that we define answers on challenging market demands and invent a range of appropriate solutions. Our people are also constantly focused on achieving optimum performances and continuous innovation.

**It is this dedication that enables us to exceed both ourselves and our customers' expectations.**

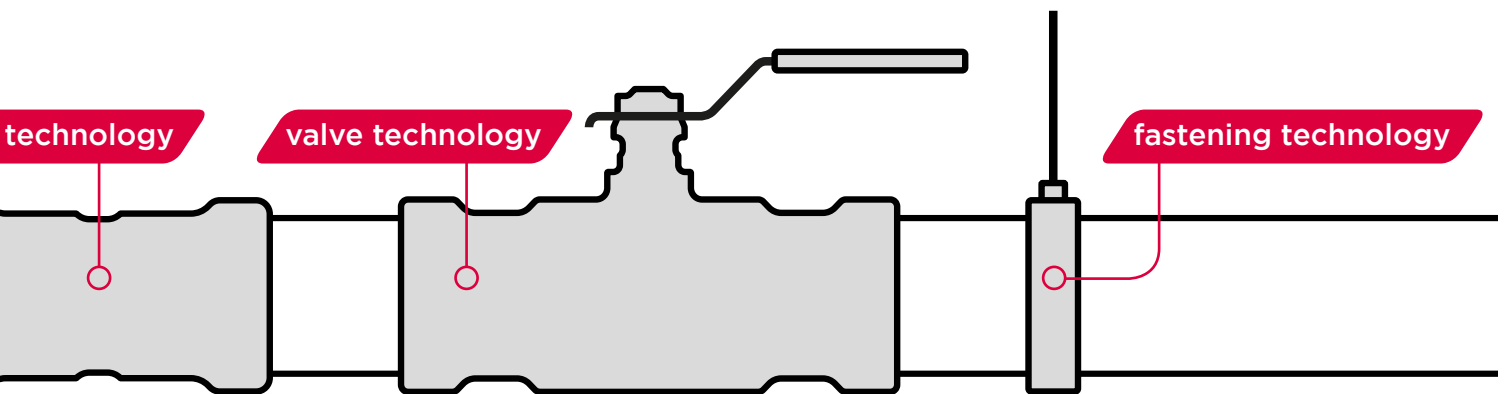

our internationally strong brands and technologies

Aalberts Integrated Piping Systems does not simply focus on only one technology within the system, but applies different technologies for different applications. All these technologies employ strong brands and together they constitute what we call our integrated piping systems. Our systems are easy to specify, install and maintain.

• **valve technology.** Thanks to the internationally renowned brands Apollo and Pegler, Aalberts Integrated Piping Systems can offer the best valves for a wide range of market segments. Naturally these valves are high quality and distributed worldwide.

• **connection technology.** With the high-quality solutions from VSH, Aalberts Integrated Piping Systems is a market leader in connection technology. The wide range of solutions is suitable for numerous applications in residential, commercial and industrial buildings, general industrial usage, fire protection and shipbuilding.

• **pipng technology.** Piping technology includes a complete range of carbon steel, stainless steel and plastic tubes in sizes ranging from 12 mm to 108 mm.

• **fastening technology.** Smart hangers for the optimal arrangement of the integrated piping system

# VSH

VSH provides the best solutions for integrated piping systems. This term encompasses a range of product lines for connection technology and valve technology which, together with our Design Service, offer the ultimate solution for top-quality integrated piping systems.



material	carbon steel
suitable for	thick walled steel
connection	press / DW-profile
dimensions	1/2" - 2" (DN15 - DN50)



material	ductile iron / stainless steel
suitable for	thick walled steel / stainless steel / HDPE
connection	groove
dimensions	1/2" - 104" (DN15 - DN2600)



material	carbon steel / stainless steel / copper / cupifer
suitable for	thin walled steel / carbon steel / stainless steel / copper / cupifer
connection	press / M-profile
dimensions	12 - 108 mm (DN10 - DN100)

## VSH piping systems ranges

VSH offers a series of product ranges that connect seamlessly:

- dimensions from 6 mm up to 104"
- thick-walled and thin-walled metal or plastic snap-on sling
- press, compression, groove and push connections
- large selection of valves and accessories

The integrated piping systems stand out due to their high and consistent quality, and quick and simple installation and maintenance. VSH offers the widest, most comprehensive range of reliable press, compression, groove and push systems - including fittings for thick-walled and thin-walled metal and plastic tubes.

### Aalberts Integrated Piping Systems Design Service®

VSH is a fully customer-focused sales and service organisation with experts who are committed to product development, service and customer support every single day. This means that from day one at the digital drawing board, you will receive professional advice on customised total solutions while being able to rely on optimum availability and reliable support both during and after delivery. Our engineers have access to all Aalberts Integrated Piping Systems products and can therefore always find the best solution which is fully customised to your needs.



### VSH SudoPress



material	carbon steel / stainless steel / copper
suitable for	thin walled steel / stainless steel / copper
connection	press / V-profile
dimensions	12 - 108 mm (DN10 - DN100)

### VSH MultiPress



material	PPSU / brass
suitable for	multilayer tube
connection	press / U & TH profile
dimensions	14 - 63 mm (DN10 - DN50)

### VSH Super



material	brass
suitable for	carbon steel / thin walled stainless steel / copper / multilayer tube
connection	compression
dimensions	6 - 54 mm (DN4 - DN50)

### VSH Tectite



material	brass / stainless steel / copper
suitable for	thin walled stainless steel / copper
connection	push
dimensions	10 - 54 mm (DN8 - DN50)

## VSH Connection technology

VSH has been supplying quality products within the piping installation sector for more than 85 years. From our own production plant in the Netherlands, we deliver our piping systems and fittings throughout Europe and beyond. Originated from 4 metalworking companies, VSH developed very rapidly. In the 1970s VSH brought the well-known VSH Super compression fitting on the market which is still a best-seller, followed by the VSH XPress pressfitting, a technology that makes it possible to realize a connection even faster and more reliable.

Dynamic, innovative, performance- and result-oriented are key words that are at the heart of VSH every day. Despite working on a global level, we can quickly switch to a local level and we will continue to invest in innovation. This is how VSH has become successful. And we are determined to stay that way!

## the strength of VSH

- the perfect solution for every project
- smart, fast and efficient installation
- Aalberts Integrated Piping Systems Design Service
- valuable advice from the drawing board to delivery
- a very wide product range
- warranty Plus
- all products are BIM now



## VSH PowerPress®

The VSH PowerPress® product range is a press system designed for thick wall carbon steel tubes according to the EN10255, EN10220, EN10216-1, EN10217-1 and ASTM A53, A106, A135, A795 (schedule 10 to 40) standards. Using the VSH PowerPress® system significantly reduces installation times and ensures a clean working environment.

### the advantages of VSH PowerPress®

- complete range of fittings and valves from 1/2" to 2"
- Visu-Control® ring: visual press indicator
- Leak Before Press (LBP) function
- simple, fast connection technology
- clear identification of material and dimensions
- professional press tools

The VSH PowerPress® system offers installers a complete solution with high flexibility. The VSH PowerPress® consists of fittings, valves and tools and can be used on standard carbon steel tubes. VSH PowerPress® fittings can be installed with various press tool brands.

### performance guaranteed

VSH PowerPress® products are produced using specially developed, ultra-modern machinery, which enables VSH to guarantee a consistent supply and quality. The completely automated factory supplies safe, high-quality products. All welded products undergo a 'leak test' to avoid any problems after installation. All straight connectors with a threaded end are made from a single piece so there is no risk of leakage on the weld and the installation measurements are compact.

### reliable

With the VSH PowerPress® the quality of the joint is primarily determined by the tool and not by the installer. This reduces the risk of installation errors considerably. All fittings are delivered with an LBP function. As a result, the risk of errors during installation is further reduced. This LBP function ensures that fittings, which have not been pressed, will leak during the initial pressure test. The installer can see immediately which fitting has not yet been pressed.



high-tech production location for VSH PowerPress®



In addition to the LBP function, all fittings are equipped with a patented Visu-Control® ring. During pressing, the Visu-Control® ring will snap from the fitting, immediately showing which fitting has been pressed. This eliminates the need to check already pressed fittings afterwards, which offers additional safety and saves time.

### cheaper

This connection technology is easy, fast and highly cost effective. As the connection is achieved using press tools alone, no other materials, such as gases, adhesives, threading machines, etc. need to be purchased or hired.

### easy and clean

Compared to other 'cold' connection methods, VSH PowerPress® is an extremely user-friendly solution:

- the use of VSH PowerPress® dispenses with the need for complicated clamping techniques, time-consuming preparations and drying time, making installation faster and cleaner..
- no need to thread the tubes.
- no lubrication needed for installation.
- Easy insertion of the tube into the fitting due to the special design of the fittings combined with the Visu-Control® ring.
- short radius bends ensure a compact, space-saving installation.

The above features ensure that no special skills are required for installation and that the work can be carried out in a clean, safe environment.

### safe

The installation of the VSH PowerPress® does not require any heat source (as is the case for welding or soldering) or other heavy and potentially dangerous tools. This feature makes VSH PowerPress® the ideal solution for repairs or renovation projects, since it ensures minimal disturbance at the site.





The image shows the cover of a technical data document for VSH PowerPress. The background is a dark red color with a blurred pattern of cylindrical metal parts, likely the product being advertised. The text is white and positioned in the upper half of the cover. The top part of the cover is a white curved shape that transitions into the red background.

**VSH** PowerPress®

technical data

# applications



## heating installations

VSH PowerPress® fittings with carbon steel tubes that meet the EN10220-1, EN10255, ASTM A53, A106, A135 or A795 (schedule 10 to 40) standard in closed-loop systems.

o-rings:	EPDM (black)
operating temperature:	-40 to +135°C
max. temperature (short term):	150°C
max. working pressure:	16 bar



## cooling water installations

VSH PowerPress® fittings with carbon steel tubes that meet the EN10220-1, EN10255, ASTM A53, A106, A135 or A795 (schedule 10 to 40) standard in closed-loop systems.

o-rings:	EPDM (black)
operating temperature:	-40 to +135°C
max. temperature (short term):	150°C
max. working pressure:	16 bar



## compressed air installations

VSH PowerPress fittings® with carbon steel tubes that meet the EN10220-1, EN10255, ASTM A53, A106, A135 or A795 (schedule 10 to 40) standard can be used for compressed air under the following conditions:

Water content: max. 880 mg/m<sup>3</sup>, class 3, ISO8573 part 1  
 Oil content: max. 25 mg/m<sup>3</sup>, class 5, ISO8573 part 1

class	water content [mg/m <sup>3</sup> ]	oil content [mg/m <sup>3</sup> ]	o-ring
1	3	0.01	EPDM
2	120	0.1	EPDM
3	880	1	EPDM
4	6.000	5	EPDM
5	7.800	25	EPDM
6	9.400	>25	N/A

ISO classification for compressed air

EPDM o-rings may only be used for synthetic oil or dry compressed air (not exceeding 25 mg/m<sup>3</sup>).

o-rings:	EPDM (black)
operating temperature:	-40 to +135°C
max. temperature (short term):	150°C
max. operating pressure:	16 bar

Compressed air piping systems must be properly tested as soon as the installation work is finished. The system designer and installation contractor must ensure safe methods are selected for testing the system. The methods must comply with all current health and safety regulations.

They may include testing compressed air lines with fluids or compressed air at a specific pressure, or a combination of both. For further information please refer to paragraph 'pressure test' on pagina 21. Since 30 May 2002, most pressure equipment and installations on the market have had to comply with the Pressure Equipment Directive (PED) 2014/68/EU. The Directive concerns items such as vessels, pressurised storage containers, heat exchangers, steam generators, boilers, industrial piping, safety equipment and pressure accessories. Please note that Article 3(3) of the PED applies to VSH PowerPress®. This means that only sound design and safe instructions for use and maintenance are required.



## sprinkler installations

VSH PowerPress fittings with carbon steel tubes that meet the EN10255 (medium and heavy classification), ASTM A53, A106, A135 or A795 (schedule 10 to 40) standard

Application: wet sprinkler installations in accordance with FM

o-rings:	EPDM (black)
operating temperature:	-40 to +107°C
max. temperature (short term):	150°C
max. working pressure:	12.1 bar (175 psi)



## vacuum installations

VSH PowerPress® fittings with carbon steel tubes that meet the EN10220-1, EN10255, ASTM A53, A106, A135 or A795 (schedule 10 to 40) standard in closed-loop systems.

VSH PowerPress® is suitable for vacuum applications with a relative pressure of -0.85 bar.



# fittings

## technical characteristics

carbon steel and protected against corrosion by a zinc-nickel coating of 3-5 µm. The zinc-nickel coating provides protection from exposure to condensation, which can form on cooling installations. The VSH PowerPress® fittings are fitted with an EPDM o-ring.

## threaded fittings

The VSH PowerPress® range also contains components with inner and outer threads and is produced in accordance with ISO7-1 or ISO228. With threaded couplings, we recommend that the sealing be performed before pressing in order not to stress the press connection.

## marking of VSH PowerPress® fittings

VSH PowerPress® fittings		
	marking	packaging label
	VSH PowerPress® dimension certificates traceability code country of origin	VSH PowerPress® type dimension EAN no. certificates art. no. number

## o-rings

The standard fittings are fitted with an EPDM profiled o-ring. The o-ring has been designed so that a leak-tight connection is always guaranteed, even with uneven surfaces.

o-ring EPDM - black		
	temperature	applications
	-40 to +135°C For a short period +150°C	For all installations for hot and cold water, circulation, compressed air, sprinklers, etc.



## Leak Before Press (LBP) function

VSH PowerPress® is equipped with an LBP function. Fittings with an LBP function have the advantage that connections that have not been pressed will leak water during pressure testing. This means that an incomplete press connection can easily be identified. If correctly assembled, the fittings will be water and air tight after being pressed.



## alternative applications

The choice of fittings and tubes depends on what the purpose of the system is, the medium to be transported and the operating conditions. Please contact us regarding approval for the use of VSH PowerPress® fittings for applications other than for heating, cooling, sprinklers and compressed air. Installations must always comply with local regulations.

## electrical heat tracing

VSH PowerPress® may be used with electrical heat tracing in order to maintain the tube temperature. Sealed tubes must not be heated because of the danger posed by the excessive and inadmissible increase in pressure in the tubes.

## equipotential bonding

All metal piping systems using equipotential bonding must comply with the requirements. Continuity checks must be conducted by a qualified electrician in accordance with the regulations, once the installation work has been finished. In combination with the associated tubes, VSH PowerPress® is an electrically conductive piping system and must therefore be included in the equipotential bonding.

# tubes

## carbon steel tubes for VSH PowerPress®

VSH PowerPress® fittings and accessories in the dimensions 1/2" up to and including 2" must be combined with carbon steel tubes in accordance with EN10220, EN10216-1, EN10217-1, EN10255 and ASTM A53, A106, A135 and A795. These tubes can be supplied as black steel, industrially painted, galvanized or epoxy coated. Special care should be taken when installing coated tubes. This section gives you all technical parameters that are especially relevant when working with VSH PowerPress® and carbon steel tubes.

## insulation

The following must be observed when insulating steel piping systems:

- cold water lines must be protected against condensation in line with DIN4140.
- hot water lines must be insulated to prevent heat loss in accordance with the Energy Conservation Act (EnEG).

## tube surfaces

Tube surfaces for each type of must be smooth, free of indentations, pits and deformations and must be clean and free of debris, rust, scale, oil and grease.

It is not necessary to completely remove protective coatings or to expose the bare steel material. To avoid leak paths, engraved or stamped tubes shall not be used with VSH PowerPress® fittings or valves (removing the engraving or stamping through the use of a grinder or other tool does not change this).

## painted black (and lacquered) tube

The tubes must be inspected for uneven layers of paint. If excessive paint runs are existing, the surface of the tube shall be smoothed by means of fine grit sand paper.

## epoxy coated carbon steel tube

Epoxy coatings on carbon steel tube increase the external dimensions. The thickness of the coating should be reduced to allow the installation of the VSH PowerPress® products. The maximum permitted thickness of the epoxy coating is 300 µm. The surface of the tube should be smoothed by means of fine grit sand paper.

## tubes according EN 10220

VSH PowerPress® can be used in combination with the EN10220 tube series 1. Series 2 and 3 are not released in combination with VSH PowerPress®.

dimension	DN	external diameter [mm]			wall thickness [mm]
		d	min.	max.	
1/2"	15	21.3	21.0	21.8	2.0 - 5.4
3/4"	20	26.9	26.5	27.3	2.0 - 8.0
1"	25	33.7	33.3	34.2	2.0 - 8.8
1 1/4"	32	42.4	42.0	42.9	2.0 - 10.0
1 1/2"	40	48.3	47.9	48.8	2.0 - 12.5
2"	50	60.3	59.7	60.8	2.0 - 16.0

tubes in line with EN10220 (series 1)

## tubes in line with EN 10255

VSH PowerPress® can be used in combination with tubes in line with EN10255. EN10255 differentiates between heavy tube (series H), medium type (series M) and type L, I1 and I2. Within these series, there are both longitudinal welded and seamless tube types.

dimension	DN	external diameter [mm]			wall thickness M- medium [mm]	wall thickness H - heavy [mm]
		d	min.	max.		
1/2"	15	21.3	21.0	21.8	2.6	3.2
3/4"	20	26.9	26.5	27.3	2.6	3.2
1"	25	33.7	33.3	34.2	3.2	4.0
1 1/4"	32	42.4	42.0	42.9	3.2	4.0
1 1/2"	40	48.3	47.9	48.8	3.2	4.0
2"	50	60.3	59.7	60.8	3.6	4.5

tubes in line with EN10255 (series M and H)

dimension	DN	external diameter [mm]			wall thickness [mm]
		d	min.	max.	
1/2"	15	21.3	21.0	21.7	2.3
3/4"	20	26.9	26.4	27.1	2.3
1"	25	33.7	33.2	34.0	2.9
1 1/4"	32	42.4	41.9	42.7	2.9
1 1/2"	40	48.3	47.8	48.6	2.9
2"	50	60.3	59.6	60.7	3.2

tubes in line with EN10255 (series I and I1)

dimension	DN	external diameter [mm]			wall thickness [mm]
		d	min.	max.	
1/2"	15	21.3	21.0	21.3	2.0
3/4"	20	26.9	26.4	26.9	2.3
1"	25	33.7	33.2	33.8	2.6
1 1/4"	32	42.4	41.9	42.5	2.6
1 1/2"	40	48.3	47.8	48.4	2.9
2"	50	60.3	59.6	60.2	2.9

tubes in line with EN10255 (series I2)

**tubes according ASTM**

VSH PowerPress® can be used in combination with carbon steel tubes in line with ASTM A53, A106, A135 and A795. Within these series, there are both longitudinal welded and seamless tube types.

dimension	DN	external diameter [mm]	schedule	wall thickness [mm]
1/2"	15	21.3	10	2.11
			40	2.77
3/4"	20	26.7	10	2.11
			40	2.87
1"	25	33.4	10	2.77
			40	3.38

dimension	DN	external diameter [mm]	schedule	wall thickness [mm]
1 1/4"	32	42.2	10	2.77
			40	3.56
1 1/2"	40	48.3	10	2.77
			40	3.68
2"	50	60.3	10	2.77
			40	3.91

*dimensions of the tubes in line with ASTM*



*black steel*



*galvanized carbon steel*



*with epoxy coating*

## press tools



Press tools consist of a press machine and the corresponding press jaw or sling. The press machine can be either battery or electrically powered. The corresponding press slings must be used for each diameter of tube in the system in order to achieve a perfect connection. The figure below shows a cross-section of the PowerPress® profile before and after pressing.



before pressing

after pressing

All VSH PowerPress® products with a diameter of 1/2" to 2" can be pressed using the appropriate press tools. Use the DW profile that matches the diameter for installation of VSH PowerPress® (VSH XPress and VSH SudoPress jaws and slings cannot be used for VSH PowerPress® with the exception of the transition fittings to VSH XPress and VSH SudoPress). A special adaptor may be required in addition to the press slings.

### maintenance and correct usage of press tools

VSH guarantees an excellent press connection, provided the tools are used correctly. Regular maintenance and lubrication of the press jaws, slings and tools is necessary. Please observe the manufacturer's instructions for use and maintenance. Poorly maintained and/or damaged press jaws pose a risk.

### approved press tools for VSH PowerPress®

dimension	make	press tool	press saws/slings
1/2" - 2"	Novopress	ECO1 Pressboy (230V) ECO201/202/203 (230V) ACO1 Pressboy (12V) ACO201 (14.4V) ACO202/203 (18V) EFP2 (230V) EFP201/202/203 (230V) AFP201/202 (14.4V) ACO202/203(XL) ACO203BT(XL) (18V)	VSH PowerPress® DW profile jaws or Novopress jaws: 1/2"- 1" Slings: 1 1/4" - 2" with adaptor ZB203
1/2" - 2"	Milwaukee	M18 (18V)	Milwaukee M18 jaws: 1/2" - 1" Milwaukee M18 slings: 1 1/4" - 2" with adaptor ZB203
1/2" - 2"	Ridgid	RP10-S (230V) RP10-B (12V) RP330C/330B RP340C/340B	Viega jaws: 1/2" - 1" (4299.9) Viega slings: 1/2" - 3/4" with adaptor z1 Viega slings: 1 1/4" - 2" with adaptor z2
1/2" - 3/4"	Viega	Picco (18V) Pressgun Picco (18V)	Viega jaws: 1/2" - 3/4" (4284.9) Viega slings: 1/2" - 3/4" with adaptor P1
1/2" - 2"	Viega	PT3-EH (230V) PT3-AH (12V) Pressgun 4E (230V) Pressgun 4B (18V) Pressgun 5	Viega jaws: 1/2" - 1" (4299.9) Viega slings: 1/2" - 3/4" with adaptor z1 Viega slings: 1 1/4" - 2" with adaptor z2
1/2" - 3/4"	Nussbaum	Pressgun Picco (18V)	Viega jaws: 1/2" - 3/4" (4284.9) Viega slings: 1/2" - 3/4" with adaptor P1
1/2" - 2"	Nussbaum	type 2 type 3 type 5A type 5 type 6	Viega jaws: 1/2" - 1" (4299.9) Viega slings: 1/2" - 3/4" with adaptor z1 Viega slings: 1 1/4" - 2" with adaptor z2

press tools approved for VSH PowerPress®



# installation guidelines

When installing VSH PowerPress®, always make sure to take proper care in using protective gear on the building site. Safety shoes, a safety helmet and safety glasses should be worn at the minimum when installing VSH PowerPress®.

## 1. transport and storage

When transporting and storing VSH PowerPress® fittings or valves, damage and contamination must be avoided. The optimal storage temperature is between 10°C and 25°C. The products should be stored in their original packaging in a dry place (max. humidity 65%). It is advised to not remove the product from the packaging before installing.

## 2. cut the tube to length



After measuring, the tubes can be cut to length using a tube cutter, a fine-toothed handsaw or an electrical mechanical saw suitable for the tube material. The tube must always be cut completely through. Do not partially cut the tube and break it off, as this could

cause leakage. When cutting already installed tubes, always take into account a minimum distance to welds and bends of 3 x d (minimum 100 mm).

**Note:** Do not use oil-cooled saws, grinding wheels or flame cutters.

## 3. deburring the tube



Tube ends must be thoroughly deburred on the inside and the outside once they have been cut to length. This is necessary to avoid any damage to the o-ring when inserting the tube into the press fitting. A file or hand deburrer or an electrical tube deburrer suitable for the

material may be used to deburr both the inside and outside of the tube. Any burrs on the tube should be removed.

## 4. cleaning the outside of the tube

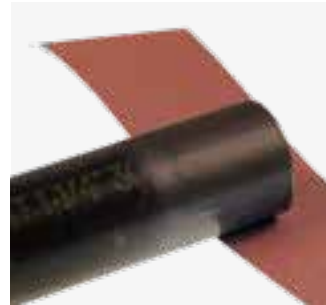

free of oil and grease.

Always ensure that any dirt, scale, excessive paint or corrosion particles are removed from the surface of the tube. This can be done with a wire brush or fine grit sand paper. The surface of the tube must be smooth, free of indentations, pits and deformations and must be

## 5. marking insertion depth



union) after the connection is pressed to identify any movement before or after pressing.

The required insertion depth (see pagina 18) must be marked on the tube or the press fitting (for fittings with tube ends) in order to guarantee a safe and proper joint.

The marking on the tube must remain visible (close to the

## 6. check the fitting and tube



pressing.

The protective cap must be removed before assembly. Then check whether the o-rings are present and firmly seated. Ensure that both are clean, in good condition and free from damage and imperfections. Make sure that the Visu-Control® ring is properly aligned before

## 7. fitting the tube



insertion depth. Rough and careless insertion of the tube into the fitting may result in damage to the o-ring. This is therefore not permitted.

Insert the tube carefully into the press while turning it and pushing it in the direction of the axis until it comes to a stroke stop in the union. The insertion depth marking must remain visible. In the case of fittings without a stop the fittings should be inserted at least as far as the marked

If assembly is difficult because of the permitted tolerances in size, a lubricant, such as water or soap, may be used. Under no circumstances may oils, fats or grease be used as lubricants.

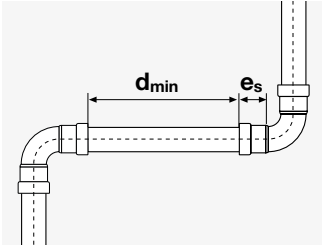

To optimise the installation time, time may be saved by first assembling a number of connections and then pressing the various tube connections one after the other.

Marking the insertion depth ( $e_s$ ) makes it possible to check whether the tube was pressed out of the union during the pressing process. Prior to installation of the various tube connections, it is important to check the minimum desired clearances (see table).

dimension	insertion depth $e_s$ [mm]	minimum distance $d_{min}$ [mm]	minimum tube length $2 \times e_s + d_{min}$ [mm]
1/2"	29	5	63
3/4"	32	5	69
1"	37	5	79
1 1/4"	49	10	108
1 1/2"	50	10	110
2"	54	10	118

*insertion depth and minimum distances between push-fit joints when using Novopress press tools*

The table gives the minimum required working space so that the fittings/valves can be pressed correctly using Novopress press tools. These distances relate to the general installation configurations as schematically depicted in figures 1, 2 and 3 below. Consult the relevant user manual when using another type of press tool.

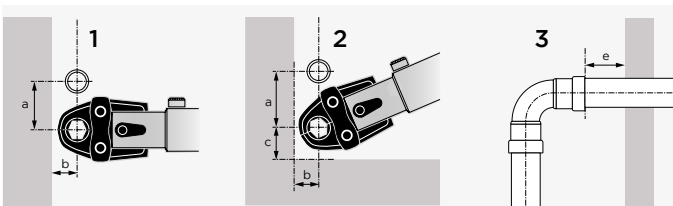

dimension	figure 1		figure 2			figure 3
	a	b	a	b	c	e
1/2"	70	30	70	30	50	30
3/4"	80	40	90	40	60	30
1"	90	40	95	40	65	30
1 1/4"	100	75	100	75	75	30
1 1/2"	115	80	115	80	85	30
2"	125	80	125	80	90	30

*required installation space when using Novopress press tools*

## 8. pressing

Before starting to press, the press jaws and slings must be checked for dirt, which should be removed if present. To create a correctly pressed connection, the press tool should enclose the collar of the fitting. Once the pressing cycle starts, it should be completed before releasing. Under no circumstances interrupt the process. Please consult our online tool selector for the most recent overview of approved machines, press jaws and slings: [www.vsh.nl/presstool](http://www.vsh.nl/presstool).

it is not permitted to press a connection more than once.



The pressing process can cause deflection (angular displacement). This behaviour can be corrected by adapting the position of the press jaw/sling on each connection. As an example, you could choose to place the machine on the left side first of all; then, for the next connection, the machine would be placed on the right side. The deflection of the joint is not something that can be prevented, but it can be minimized using the above method.

## corrosion protection

If VSH PowerPress® fittings are used in an application where full corrosion protection is needed, always take care to protect the tube surface.

# general installation information

## thermal expansion

The level of thermal expansion within piping systems depends on the type of materials used. This linear expansion needs to be taken into account during the installation. Minor changes in length can be accommodated by having adequate space for expansion as well as by the elastic properties of the piping system itself. More substantial changes in length need to be offset by other means, e.g. installation of special expansion compensation devices, fixed anchoring points and sliding points.

Expansion can be offset by the use of a tube segment, U-bend or compensators. The level of expansion to be offset can be determined beforehand by calculating the changes in length.

The equation for calculating the changes in length is as follows:

$$\Delta l = l \times \alpha \times \Delta T$$

- $\Delta l$  = total linear expansion in [mm]
- $l$  = length of the segment in question [m]
- $\Delta T$  = temperature difference [K]
- $\alpha$  = linear coefficient of expansion

## pressure loss

Every fluid that flows through a piping system experiences continuous and local flow resistance. This is called pressure loss. There is a difference between continuous and local pressure losses. A continuous pressure loss is primarily caused by the flow resistance in straight tube sections, which is essentially the result of the friction between the fluid and the tube wall. Local pressure loss, on the other hand, are caused by the flow resistance at a number of places on the circulation system, such as a change in the internal diameter, a tube branch, an elbow, etc.

## continuous pressure loss

To calculate the resistance of a fluid flow in a straight section of a piping system, first determine the resistance in a unit of length and then multiply the total length by this value. This value can be determined analytically using the Hazen-Williams formula.

$$p = \frac{6.05 \times 105}{C^{1.85} \times d_i^{4.87}} \times Q^{1.85}$$

- $p$  = pressure loss in the tube [bar/m]
- $Q$  = flow [l/m]
- $d_i$  = internal diameter of the tube [mm]
- $C$  = constant for type and condition of the tube

If you wish to perform these calculations, please consult the relevant specialised literature.

## local pressure loss







A local pressure loss is the flow resistance that is the result of changes in the flow direction, changes in diameter, flow splitting over multiple channels, etc. There are, in principle, two ways of calculating such flow resistance: the direct analytical method and the method that uses "equivalent lengths".

## equivalent length method

This method assumes that pressure loss at a particular point can be considered to be the same as an equivalent increase in the length of a straight piping system with the same internal diameter. The final result is a pressure loss that is equal to the real pressure loss. In other words, the equivalent lengths of the individual joints are added to the actual length of the piping system (see below).

The actual length is then multiplied by the pressure loss per unit length to be able to calculate the total system pressure drop. This method is not as accurate as the direct method but has the advantage that the calculation can be carried out faster.

direct analytical method [ $\zeta$ ] / equivalent length method [m]

OD	DN												
		$\zeta$	[m]	$\zeta$	[m]	$\zeta$	[m]	$\zeta$	[m]	$\zeta$	[m]	$\zeta$	[m]
3/4"	20	0.61	0.37	0.51	0.32	0.38	0.24	0.96	0.59	0.32	0.20	-	-
1"	25	0.64	0.53	0.54	0.46	0.42	0.35	1.06	0.89	0.29	0.24	0.32	0.20
1 1/4"	32	0.51	0.62	0.38	0.47	0.32	0.39	0.93	1.13	0.26	0.31	0.35	0.29
1 1/2"	40	0.45	0.65	0.32	0.47	0.29	0.42	0.83	1.22	0.22	0.33	0.26	0.31
2"	50	0.48	0.94	0.35	0.69	0.29	0.57	0.93	1.82	0.22	0.44	0.26	0.38

equivalent lengths and zeta values

### direct analytical method

The local pressure drop can be calculated using the following equation:

$$\Delta p_L = \sum \zeta \times v^2 \times \gamma / 2 \times 10^{-5} \text{ [bar]}$$

- v = flow velocity of the fluid [m/s]
- γ = specific density of the fluid [kg/m<sup>3</sup>]
- ζ = local flow resistance coefficient

The table above shows the zeta [ζ] value for each type of fitting. We can assume that the zeta value is velocity independent for those velocities that occur in domestic installations or in other normal applications; this is supported by the fact that the change in zeta as a function of the Reynolds number in these velocity ranges is only minimal. Once the zeta value is known, you can calculate the corresponding local pressure drop-off using the formula above.

### heat loss

Just as with all other types of tubes made from metal or plastic, adequate measures must be taken to limit heat losses. Please consult the relevant regulations on minimum insulation thicknesses and the insulation standards.

## built-in

### welding requirements

The following requirements have to be considered when welding in the same vicinity as VSH PowerPress® products.

#### welding adjacent to already installed VSH PowerPress® fittings/valves

When welding close to an installed VSH PowerPress® connection, the installer must remain at least 10 cm away from the connection to prevent damage to the o-ring. The installer should take the following precautions to protect the VSH PowerPress® connections while welding:

- make the welded connections before the press connections are made. The tube must have cooled down before the fitting/valve is installed.
- wrap the connection in a cold, wet rag.
- protect the connection with a weld blanket.
- use spray as a coolant.

#### welding in an installation with VSH PowerPress® fittings/valves

When welding a tube with an installed VSH PowerPress® connection, the installer must remain at least 90 cm away from the connection to prevent damage to the o-ring. The installer should take the following precautions to keep the VSH PowerPress® connections cool while welding:

- make the welded connections before the press connections are made. The tube must have cooled down before the fitting/valve is installed.
- wrap the connection in a cold, wet rag.
- protect the connection with a weld blanket.
- use spray as a coolant.

### guidelines for distances of mounting brackets

Always make sure to have hangers and supports conform to local requirements. All parts of the hangers and supports must be designed and installed so that they support the piping. Always make sure to place sliding hangers so that they do not become rigid hangers by accident.

Ø tube diameter	max. distance [m]
1/2"	2.75
3/4"	3.00
1"	3.50
1 1/4"	3.75
1 1/2"	4.25
2"	4.75

*distance between mounting brackets in accordance with EN806, part 4*



Observance of the above distances between attachment points is not sufficient in itself. Heat expansion also needs to be appropriately compensated for in horizontal stretches. The distances stated above will possibly have to be adapted for this purpose.

#### mounting tubes

When securing the tubes, the following should be kept in mind: The load-bearing capacity of the mounting brackets must correspond to the weight of the (filled) tubes and withstand expansion and torsion forces. Mounting brackets, such as fixed mounting points and clips, must therefore be correctly placed and assembled.

Attachment points may only be fitted onto straight tube sections. Mounting brackets on fittings and valves is not permitted.

#### pressure test

Once a piping system has been installed it must be checked for leaks before being built in and concealed. With heating and cooling installations, the pressure test can be carried out with water, air or inert gases. The test medium and the results of the pressure test should be documented in a pressure test report.

##### IMPORTANT:

The piping system must be pressure-tested in all cases for VSH PowerPress®. Before being covered up, insulated, painted or walled in, a piping system must first undergo a pressure test to be certain that there are no leaks. Pressure tests must always be performed in accordance with local regulations. As a rule of thumb, a pressure of 1.5 times the operating pressure is used for pressure tests with water.

##### IMPORTANT:

When testing a VSH PowerPress® installation, make sure no water remains in the system afterwards, in order to avoid the risk of corrosion, unless the system is going to be put into service shortly afterwards.

#### pressure test for heating systems and cooling systems

##### IMPORTANT:

As a rule, the pressure test for piping that has already been laid is carried out with water in accordance with DIN-VOB 18380.

- the test pressure at each point of the system must be 1.3 times the operating pressure with overpressure of at least 1 bar
- immediately after the cold water pressure test, the water must be heated up to the highest hot water temperature on which the calculations were based in order to be certain that the system remains watertight at high temperatures
- there must be no drop in pressure during the pressure test
- the pressure test must be adequately documented

#### pressure test with air

##### IMPORTANT:

The pressure test with air or inert gases can be carried out in accordance with the ZVSHK/BHKS technical bulletins, "Pressure Test with Air or Inert Gases", (at 100 l tube capacity a leak tightness test at 110 mbar for at least 30 minutes. For every additional 100 l, the time must be increased by 10 minutes. After the leak tightness test, the strength of the connection is to be tested during 10 minutes at: max. 3 bar up to and including DN50). For safety reasons, the maximum test pressure is set at 3 bars.

#### pressure testing of sprinkler systems

The tubes of a sprinkler system must be subjected to a pressure test in accordance with the applicable standards such as CEA 4001, no. 17.1.1. (VdS) for at least two hours. A pressure (measured at the alarm valves) corresponding to 1.5 times the permitted positive operating pressure – but of at least 15 bars – must be maintained during the test. This pressure test is a check of both the strength and tightness of the system. The system must be monitored for 24 hours for any pressure drop due, for example, to temperature changes. Any faults identified, such as permanent deformations, ruptures or leakages must be corrected and the pressure test repeated.

## corrosion

There are different kinds of corrosion: chemical corrosion, electro-chemical corrosion, internal and external local corrosion, stray current corrosion, etc. All these kinds of corrosion have very particular chemical or mechanical causes. The following paragraphs provide some simple hints on how to avoid such problems.

### electro-chemical corrosion

Electro-chemical corrosion occurs under the following circumstances:

- electrochemical potential difference between both parts.
- presence of a conductive fluid (electrolyte), such as water.
- presence of oxygen.

If heating installations are installed and used properly, they will not contain a substantial amount of oxygen, making the risk of corrosion small. It is critical that the VSH PowerPress® system components be installed only downstream of other, metallurgically inferior (lower quality) components that may be present in these kinds of installations. A branch can, for example, be made with VSH XPress stainless steel. In such a case, a non-ferrous metal or synthetic connection piece must be used (see DIN1988).

Another important factor is the ratio between the surface of the noble metal and that of the less noble metal. The higher this ratio, the greater the corrosion rate may be.

### stray currents

Corrosion by stray currents rarely occurs in practice and is immediately recognisable as it starts on the outside of the tube with a cone-shaped crater to the inside. Stray current corrosion requires a direct current that turns the metal into an anode. The current which in practice – in spite of insulation measures – penetrates into the earth and other metal structures in the vicinity goes through part of the system first of all and only then back to earth. To penetrate into the piping system, the earth current must have an entry point at a spot where the normal protective cover of the tube or connection is damaged or missing.

For this reason, metal piping systems must be earthed (see EU Regulations). Direct current installations are generally not used in domestic households and no real problems occur with alternating current.

### carbon steel tubes

#### internal corrosion

Internal corrosion cannot occur with closed-loop water heating systems. The oxygen in the water in closed-loop systems creates a layer of iron oxide on the inside of the tube thereby preventing any further corrosion. When the heating system is not in use, it must be kept filled at all times or, alternatively, be completely drained and subsequently dried out, to avoid the presence of water and oxygen in the system at the same time.

The necessary additives should be added to prevent frost damage, calcification or corrosion. We are always pleased to answer any enquiries about the use of additives. Please observe the applicable legislation, regulations and local rules regarding corrosion.

#### external corrosion

Steel piping systems are generally installed in such a way that the outer surfaces do not come into contact with corrosive media. If this does nevertheless occur, appropriate measures must be taken.

#### prevention of corrosion

Instructions will be found in the following paragraphs on how to prevent corrosion problems in the most usual places. A distinction is made between inner and outer corrosion, and the area of application.

### internal corrosion

#### heating installations

The penetration of oxygen in closed-loop heating installations will be prevented if high-quality accessories and compensators with closed membranes are used. When filling the installation, the small quantity of oxygen contained in the water is directly absorbed into the inner tube surface, in the process of which a thin layer of iron oxide is formed and after which there is no longer any possibility of corrosion. The loss in wall thickness can be disregarded. The loss in wall thickness is negligible. The heating water is virtually free of oxygen following this reaction.

#### carbon steel tubes

Internal corrosion is normally impossible in closed-loop heating installations as oxygen from outside cannot penetrate the installation.

#### water additives

Oxygen scavengers and corrosion inhibitors can be added to the heating-circuit water as a preventive measure against inadmissible oxygen absorption. Observe the supplier's instructions for use.

### **external corrosion**

There are few situations in which outer corrosion occurs in buildings. It is, however, possible in many cases that installations are exposed for a longer period to undesired penetration of rain, humidity or dampness and this can lead to problems. Responsibility for taking relevant measures rests, however, with the user and the installer. Only suitable corrosion protection can offer permanent certainty against corrosion. One way of doing so is to use 'closed cell' insulation, which must be applied in a guaranteed waterproof condition.

Suitable primers - or metallic paints may offer minimal corrosion protection. It is advisable to always use corrosion protection on the piping in situations where corrosion is likely to occur (damp room, crawl spaces, etc.).

### **carbon steel tubes**

Special attention must be paid to preventing outer corrosion where an environment remains humid for longer periods.

In addition, piping systems should be properly sized to minimise the risk of erosion and corrosion resulting from excessive velocities.

### **impact of application and processing**

#### **underground installations**

VSH PowerPress® and black carbon steel tubes are approved for underground installations (with the exception of sprinkler installations). All installations must, however, comply with local regulations. Proper authorisation must be obtained prior to underground installation from the local authority having jurisdiction.

#### **galvanized carbon steel tube**

With galvanized carbon steel tube, waterline corrosion can occur as a result of interaction between three actors (water - metal - gas (air)). This corrosion can be prevented if the installation remains permanently filled once filled for the first time. Partial filling will take place, for example, if the tubes are emptied again after a pressure test with water, in which case a pressure test using gas/air is recommended.

### **insulation**

Insulation does not, as a rule, offer any protection against corrosion, except in the case of 'closed cell insulation' (sealed and watertight), which offers effective protection against corrosion. The installation instructions of the supplier of the insulation material must always be followed carefully. Remove dust, dirt, oil or water from the piping prior to insulating.

The different sections of the insulation material must be carefully joined, taking care that no moisture or water can enter the material.

Also take care that the water barrier of the insulation material is not damaged during installation as moisture could otherwise penetrate under the insulation material.

#### **insulating carbon steel**

No corrosion can occur if there is no humidity between the insulation material and the tube. If there is a possibility of damp (e.g. condensation) occurring under the insulation, the outside of the tube will corrode.







VSH PowerPress®

fittings

**C9401 straight coupling**  
(2 x press)

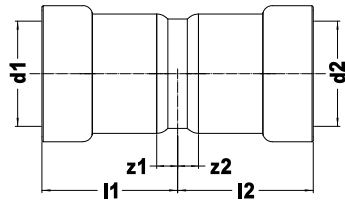

dimension	article no.	l1/l2	z1/z2
1/2"	PWR9400809	34	5
3/4"	PWR9400811	37	6
1"	PWR9400820	42	5
1 1/4"	PWR9400831	56	7
1 1/2"	PWR9400842	57	8
2"	PWR9400853	61	7

**C9403 slip coupling**  
(2 x press)

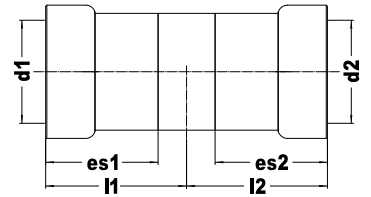

dimension	article no.	l1/l2	es1/es2
1/2"	PWR9400864	39	29
3/4"	PWR9400875	42	32
1"	PWR9400886	47	37
1 1/4"	PWR9400897	59	49
1 1/2"	PWR9400908	63	49
2"	PWR9400919	65	54

**C9408 bend 90°**  
(2 x press)

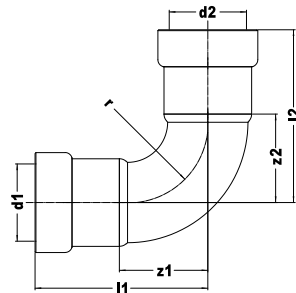

dimension	article no.	l1/l2	z1/z2	r
1/2"	PWR9400006	55	26	25
3/4"	PWR9400017	63	32	30
1"	PWR9400028	76	40	38
1 1/4"	PWR9400039	97	48	45
1 1/2"	PWR9400041	103	54	50
2"	PWR9400050	122	68	65

**C9411 bend 90°**  
(press x male)

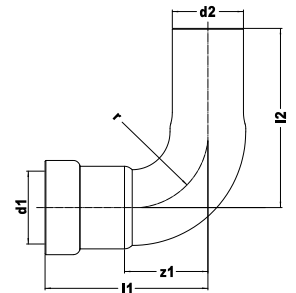

dimension	article no.	l1	l2	z1	r
1/2" x Ø 1/2"	PWR9400061	55	69	26	25
3/4" x Ø 3/4"	PWR9400072	63	75	32	30
1" x Ø 1"	PWR9400083	76	91	40	38
1 1/4" x Ø 1 1/4"	PWR9400094	97	109	48	45
1 1/2" x Ø 1 1/2"	PWR9400105	114	114	64	50
2" x Ø 2"	PWR9400116	122	140	68	65

**C9413 bend 45°**  
(2 x press)

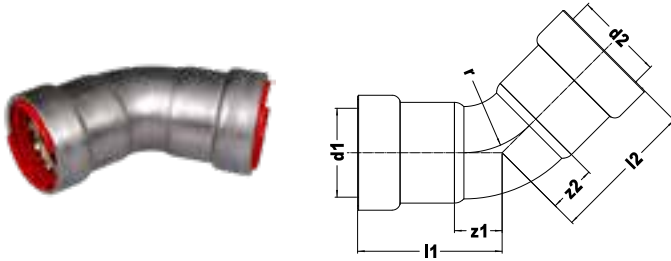

dimension	article no.	l1/l2	z1/z2	r
1/2"	PWR9400127	41	12	25
3/4"	PWR9400138	46	14	30
1"	PWR9400149	54	17	38
1 1/4"	PWR9400151	71	22	45
1 1/2"	PWR9400160	74	25	50
2"	PWR9400171	84	30	65

**C9412 bend 45°**  
(press x male)

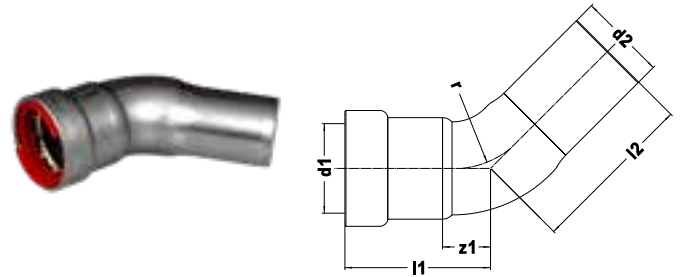

dimension	article no.	l1	l2	z1	r
1/2" x Ø 1/2"	PWR9400182	41	54	12	25
3/4" x Ø 3/4"	PWR9400193	46	58	15	30
1" x Ø 1"	PWR9400204	54	68	18	38
1 1/4" x Ø 1 1/4"	PWR9400215	71	80	22	45
1 1/2" x Ø 1 1/2"	PWR9400226	84	85	35	50
2" x Ø 2"	PWR9400237	84	98	30	65

**C9414 tee**  
(3 x press)

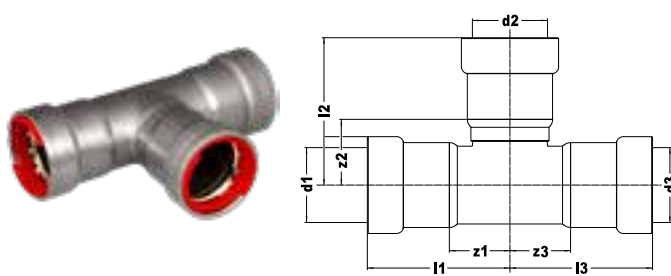

dimension	article no.	l1/l3	l2	z1/z3	z2
1/2"	PWR9400248	52	53	23	24
3/4"	PWR9400259	57	59	26	27
1"	PWR9400261	66	68	30	31
1 1/4"	PWR9400270	82	85	33	36
1 1/2"	PWR9400281	89	89	39	40
2"	PWR9400292	96	100	42	46

**C9415 tee reduced**  
(3 x press)

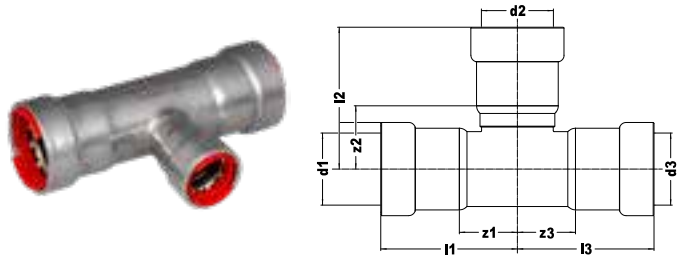

dimension	article no.	l1/l3	l2	z1/z3	z3
3/4" x 1/2" x 3/4"	PWR9400303	57	56	26	26
1" x 1/2" x 1"	PWR9400314	66	60	30	30
1" x 3/4" x 1"	PWR9400325	66	63	30	30
1 1/4" x 1/2" x 1 1/4"	PWR9400336	82	56	33	33
1 1/4" x 3/4" x 1 1/4"	PWR9400347	82	63	33	33
1 1/4" x 1" x 1 1/4"	PWR9400358	82	72	33	33
1 1/2" x 1/2" x 1 1/2"	PWR9400369	89	66	39	39
1 1/2" x 3/4" x 1 1/2"	PWR9400371	89	68	39	39
1 1/2" x 1" x 1 1/2"	PWR9400380	89	74	39	39
1 1/2" x 1 1/4" x 1 1/2"	PWR9400391	89	87	39	39
2" x 1/2" x 2"	PWR9400402	96	73	42	42
2" x 3/4" x 2"	PWR9400413	96	76	42	42
2" x 1" x 2"	PWR9400424	96	81	42	42
2" x 1 1/4" x 2"	PWR9400435	96	95	42	42
2" x 1 1/2" x 2"	PWR9400446	96	97	42	42

### C9418 tee

(press x female thread x press)

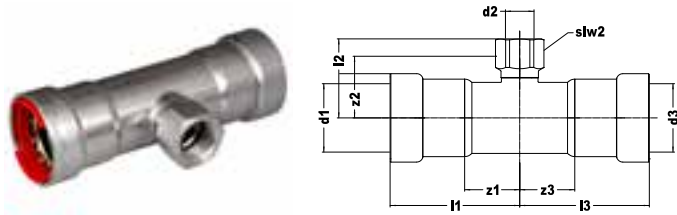

dimension	article no.	l1/l3	l2	z1/z3	z2	slw2
1/2" x Rp1/2" x 1/2"	PWR9400457	52	36	23	36	27
3/4" x Rp1/2" x 3/4"	PWR9400468	57	42	26	42	27
1" x Rp1/2" x 1"	PWR9400479	66	46	30	46	27
1" x Rp3/4" x 1"	PWR9400481	66	47	30	47	32
1 1/4" x Rp1/2" x 1 1/4"	PWR9400490	82	50	33	50	27
1 1/4" x Rp3/4" x 1 1/4"	PWR9401700	82	48	33	36	32
1 1/4" x Rp1" x 1 1/4"	PWR9401711	82	50	33	37	41
1 1/2" x Rp1/2" x 1 1/2"	PWR9400501	89	52	39	52	27
1 1/2" x Rp3/4" x 1 1/2"	PWR9400512	89	53	39	53	32
1 1/2" x Rp1" x 1 1/2"	PWR9400523	89	57	39	57	41
2" x Rp1/2" x 2"	PWR9400534	96	60	42	60	27
2" x Rp3/4" x 2"	PWR9400545	96	61	42	61	32
2" x Rp1" x 2"	PWR9400556	96	65	42	65	41

### C9407 reducer

(press x male)

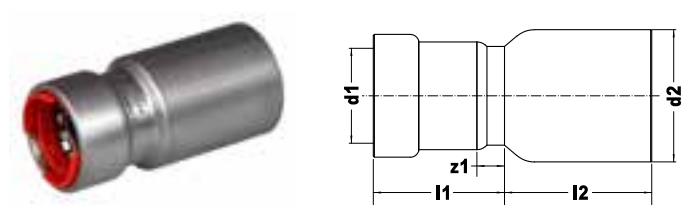

dimension	article no.	l1	l2	z1
1/2" x Ø 3/4"	PWR9400921	29	35	1
1/2" x Ø 1"	PWR9400930	29	40	1
1/2" x Ø 1 1/4"	PWR9400952	29	55	1
1/2" x Ø 1 1/2"	PWR9400985	43	65	15
1/2" x Ø 2"	PWR9401029	43	74	15
3/4" x Ø 1"	PWR9400941	32	37	1
3/4" x Ø 1 1/4"	PWR9400963	32	53	1
3/4" x Ø 1 1/2"	PWR9400996	46	63	15
3/4" x Ø 2"	PWR9401031	46	72	15
1" x Ø 1 1/4"	PWR9400974	37	48	1
1" x Ø 1 1/2"	PWR9401007	37	49	1
1" x Ø 2"	PWR9401040	50	69	14
1 1/4" x Ø 1 1/2"	PWR9401018	49	48	1
1 1/4" x Ø 2"	PWR9401051	49	48	1
1 1/2" x Ø 2"	PWR9401062	50	50	1

### C9405 straight connector

(press x male thread)

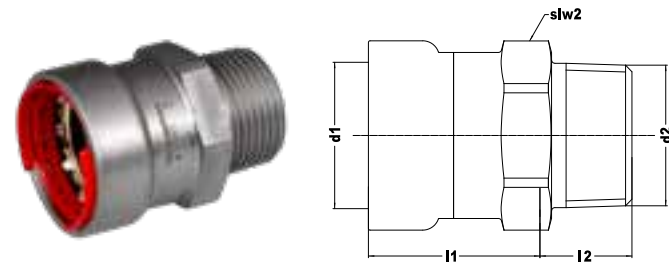

dimension	article no.	l1	l2	slw2
1/2" x R1/2"	PWR9400567	35	15	28
3/4" x R3/4"	PWR9400578	36	16	36
1" x R1"	PWR9400589	41	23	41
1 1/4" x R1 1/4"	PWR9400591	54	20	50
1 1/2" x R1 1/2"	PWR9400600	54	20	57
2" x R2"	PWR9400611	59	20	70

### C9402 straight connector

(press x female thread)

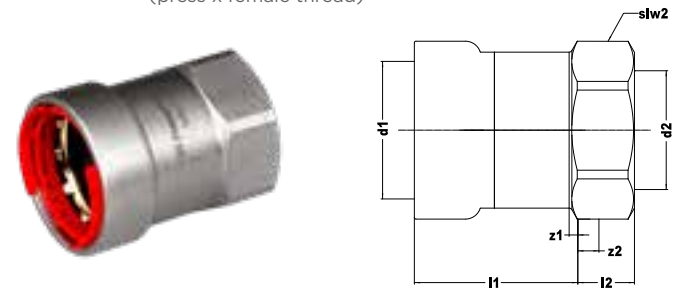

dimension	article no.	l1	l2	z1	z2	slw2
1/2" x Rp1/2"	PWR9400622	32	14	3	6	28
3/4" x Rp3/4"	PWR9400633	33	16	1	7	36
1" x Rp1"	PWR9400644	39	18	3	8	41
1 1/4" x Rp1 1/4"	PWR9400655	50	21	1	8	50
1 1/2" x Rp1 1/2"	PWR9400666	51	20	2	8	57
2" x Rp2"	PWR9400677	56	20	2	5	70

### C9435 straight union (press x male thread)

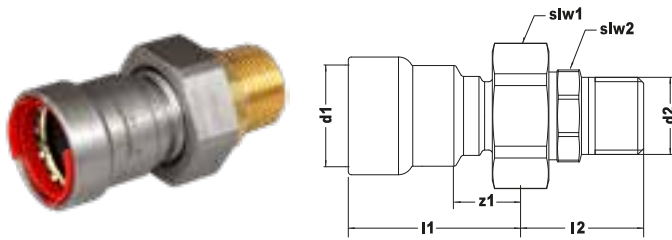

dimension	article no.	l1	l2	z1	slw1	slw2
1/2" x R1/2"	PWR9401436	48	33	19	36	25
3/4" x R3/4"	PWR9401447	53	38	22	41	32
1" x R1"	PWR9401458	59	42	23	50	39
1 1/4" x R1 1/4"	PWR9401469	73	46	24	57	45

### C9439 reducer (2 x press)

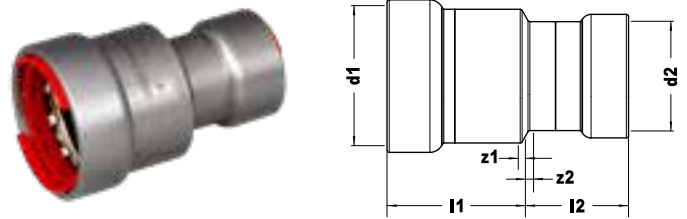

dimension	article no.	l1	l2	z1	z2
3/4" x 1/2"	PWR9401073	34	29	3	1
1" x 1/2"	PWR9401084	41	29	5	1
1" x 3/4"	PWR9401755	39	31	3	0
1 1/4" x 3/4"	PWR9401766	55	31	7	0
1 1/4" x 1"	PWR9401777	53	36	5	0
1 1/2" x 1 1/4"	PWR9401788	53	50	4	2
2" x 1 1/4"	PWR9401799	61	50	8	2
2" x 1 1/2"	PWR9401801	59	51	6	2

### C9427 flanged connector PN6 (1 x press)

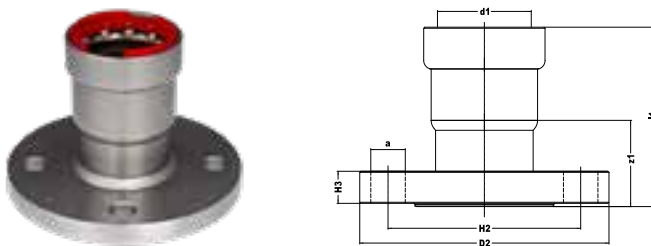

dimension	article no.	l1	z1	H2	H3	D2	a	gaten
1 1/4" (DN32)	PWR9400688	88	39	90	12	120	14	4
1 1/2" (DN40)	PWR9400699	93	43	100	12	130	14	4
2" (DN50)	PWR9400701	94	40	110	12	140	14	4

### C9426 flanged connector PN 10/16 (1 x press)

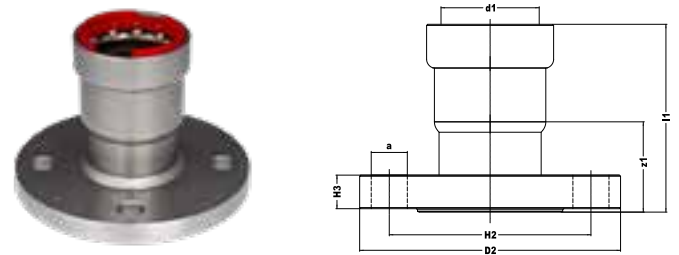

dimension	article no.	l1	z1	H2	H3	D2	a	gaten
1 1/4" (DN32)	PWR9400710	92	43	100	16	140	18	4
1 1/2" (DN40)	PWR9400721	97	47	110	16	150	18	4
2" (DN50)	PWR9400732	98	44	125	16	165	18	4



**C9429 stop end**  
(1 x press)

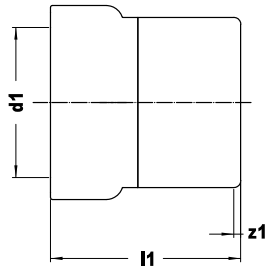

dimension	article no.	l1	z1
1/2"	PWR9400743	35	6
3/4"	PWR9400754	38	6
1"	PWR9400765	43	7
1 1/4"	PWR9400776	56	7
1 1/2"	PWR9400787	57	8
2"	PWR9400798	62	8

**C9448 transition for grooved couplings**  
(press x groove)

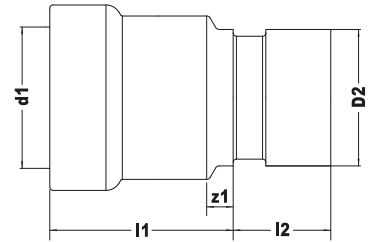

dimension	article no.	l1	l2	z1
1" x 33.7	PWR9401095	45	24	8
1 1/4" x 42.4	PWR9401106	58	24	9
1 1/2" x 48.3	PWR9401117	58	24	9
2" x 60.3	PWR9401128	63	24	9

**C9446 coupling with nut**  
(press x female thread)

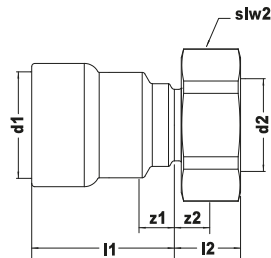

dimension	article no.	l1	l2	z1	z2	slw2
1/2" x G3/4"	PWR9401359	46	9	17	0	36
3/4" x G1"	PWR9401361	51	12	20	1	41
1" x G1 1/4"	PWR9401370	57	12	21	1	50
1" x G1 1/2"	PWR9401381	54	12	17	1	57
1 1/4" x G1 1/2"	PWR9401392	71	12	22	1	57
1 1/4" x G2"	PWR9401403	53	16	4	1	70
1 1/2" x G2"	PWR9401414	75	16	25	1	70
2" x G2 1/2"	PWR9401425	83	20	29	1	85

**C9441 transition to VSH XPress**  
(press x VSH XPress)

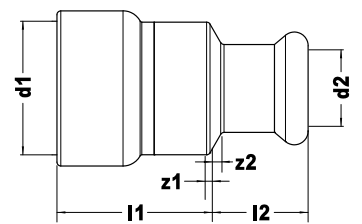

dimension	article no.	l1	l2	z1	z2
1/2" x 15	PWR9401216	30	22	1	2
3/4" x 15	PWR9401238	32	23	1	2
3/4" x 22	PWR9401227	39	24	3	4
1" x 15	PWR9401249	33	23	2	3
1" x 28	PWR9401251	38	25	1	2
1 1/4" x 35	PWR9401260	51	29	2	3
1 1/2" x 42	PWR9401271	52	33	2	3
2" x 54	PWR9401282	56	38	2	3

### C9440 transition to VSH SudoPress

(press x VSH SudoPress)

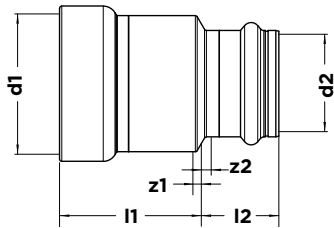

dimension	article no.	l1	l2	z1	z2
1/2" x 15	PWR9401139	32	24	3	2
3/4" x 15	PWR9401141	35	25	4	3
1" x 15	PWR9401150	41	26	5	4
3/4" x 22	PWR9401161	34	25	3	2
1" x 28	PWR9401172	39	26	3	2
1 1/4" x 35	PWR9401183	52	27	3	2
1 1/2" x 42	PWR9401194	53	39	4	3
2" x 54	PWR9401205	57	45	3	4

### C9452 flat seal

(black, EPDM)



dimension	article no.
suitable for G3/4"	PWR9401722
suitable for G1"	PWR9401471
suitable for G1 1/4"	PWR9401480
suitable for G1 1/2"	PWR9401491
suitable for G2"	PWR9401733
suitable for G2 1/2"	PWR9401502

the maximum operating temperature is limited to 120°C





VSH PowerPress®

valves

by Pegler

PP550 ball valve PN16  
(2 x press)



specifications

- maximum pressure 16 bar
- operating temperature -10 to 135°C
- lockable latching handle
- identifiable lock indication
- reversible handle insert (red/blue)
- chrome plated brass full bore ball
- PTFE ball seats

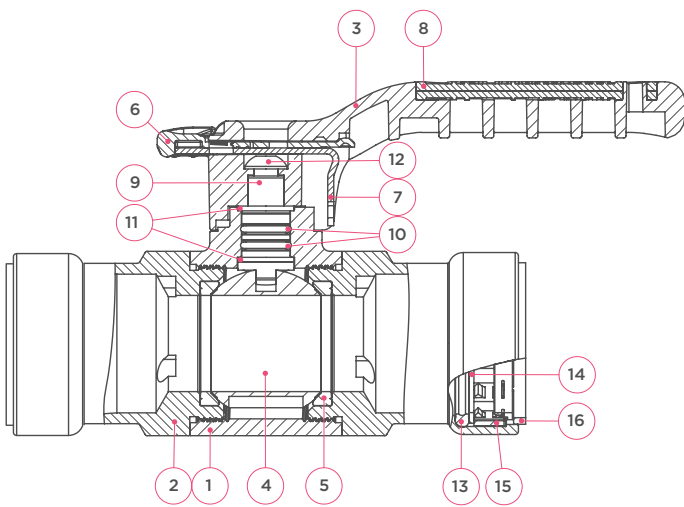

nr.	part	material
1	body	DZR brass (CW511L)
2	press end	carbon steel zinc nickel plated
3	handle	zamak
4	ball	DZR brass (CW511L)
5	seat	PTFE
6	latch grip	nylon 6
7	latch	stainless steel
8	handle insert	TPE
9	spindle	stainless steel
10	spindle seal	EPDM
11	spindle bearing	PTFE
12	screw	stainless steel
13	o-ring	EPDM
14	spacer ring	stainless steel
15	grab ring	stainless steel
16	Visu-Control® ring	polypropylene

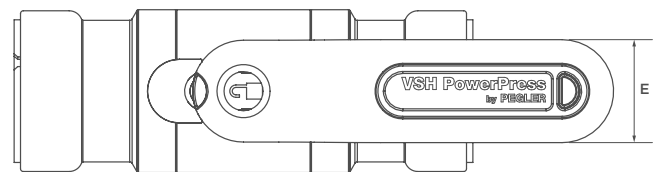
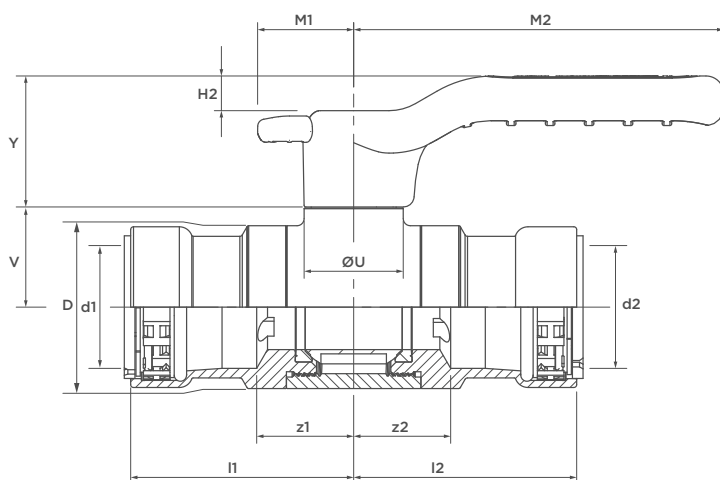

dimension	article no.	weight [kg]	Kvs [m³/h]	l1/l2	z1/z2	U	V	Y	H2	E	M1	M2	D
1/2" (DN15)	PWR9440002	0.57	17	55	27	28	23	37	10	29	27/34	105	31
3/4" (DN20)	PWR9440013	0.67	41	55	24	28	25	37	10	29	27/34	105	38
1" (DN25)	PWR9440024	0.92	70	63	28	28	28	37	10	29	27/34	105	46
1 1/4" (DN32)	PWR9440035	1.31	121	80	32	28	34	37	10	29	27/34	105	57
1 1/2" (DN40)	PWR9440046	1.76	200	83	35	28	41	37	10	29	27/34	165	66
2" (DN50)	PWR9440057	2.77	292	93	40	28	48	37	10	29	27/34	165	83



PP550 EL ball valve with extended stem PN16  
(2 x press)

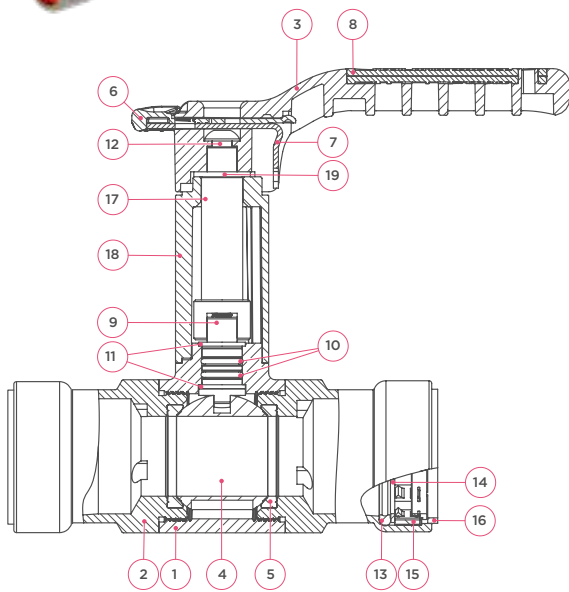

specifications

- maximum pressure 16 bar
- operating temperature -10 to 135°C
- lockable latching with extended stem
- identifiable lock indication
- reversible handle insert (red/blue)
- chrome plated brass full bore ball
- PTFE ball seats

nr.	part	material
1	body	DZR brass (CW511L)
2	press end	carbon steel zinc nickel plated
3	handle	zamak
4	ball	DZR brass (CW511L)
5	seat	PTFE
6	latch grip	nylon 6
7	latch	stainless steel
8	handle insert	TPE
9	spindle	stainless steel
10	spindle seal	EPDM
11	spindle bearing	PTFE
12	screw	stainless steel
13	o-ring	EPDM
14	spacer ring	stainless steel
15	grab ring	stainless steel
16	Visu-Control® ring	polypropylene
17	extended spindle	stainless steel
18	handle extension	zamak
19	handle extensions bearing	PTFE

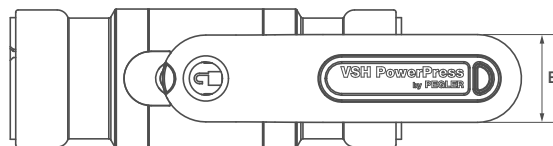
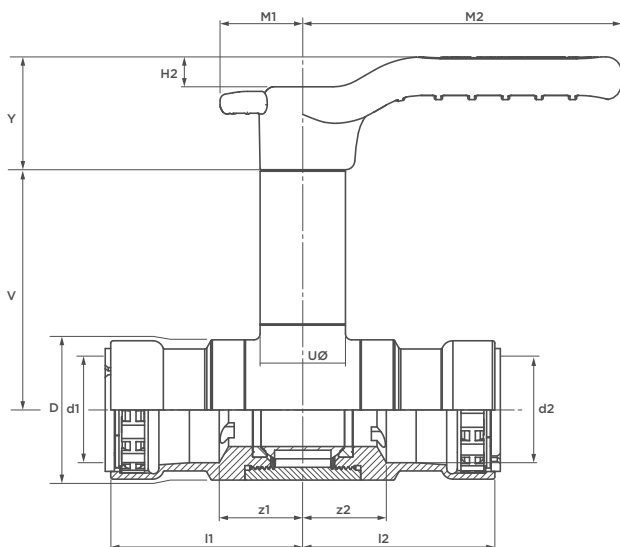

dimension	article no.	weight [kg]	Kvs [m³/h]	I1/I2	z1/z2	U	V	H2	Y	E	M1	M2	D
1/2" (DN15)	PWR9440123	0.71	17	55	27	28	74	10	37	29	27/34	105	31
3/4" (DN20)	PWR9440134	0.81	41	55	24	28	76	10	37	29	27/34	105	38
1" (DN25)	PWR9440145	1.06	70	63	28	28	80	10	37	29	27/34	105	46
1 1/4" (DN32)	PWR9440156	1.45	121	80	32	28	86	10	37	29	27/34	105	57
1 1/2" (DN40)	PWR9440167	1.90	200	83	35	28	92	10	37	29	27/34	165	66
2" (DN50)	PWR9440178	2.91	292	93	40	28	99	10	37	29	27/34	165	83

**PPSU550 ball valve PN16**  
(2 x press, with union connection)



specifications

- maximum pressure 16 bar
- operating temperature -10 to 120°C
- lockable latching handle
- identifiable lock indication
- reversible handle insert (red/blue)
- chrome plated brass full bore ball
- PTFE ball seats

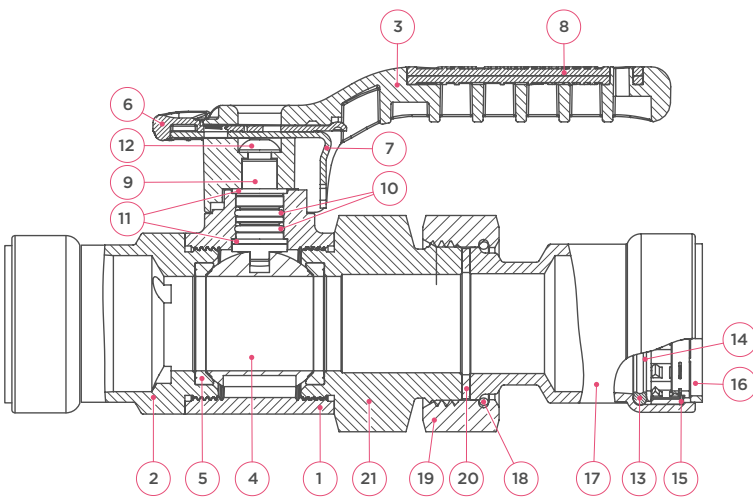

nr.	part	material
1	body	DZR brass (CW511L)
2	press end	carbon steel zinc nickel plated
3	handle	zamak
4	ball	DZR brass (CW511L)
5	seat	PTFE
6	latch grip	nylon 6
7	latch	stainless steel
8	handle insert	TPE
9	spindle	stainless steel
10	spindle seal	EPDM
11	spindle bearing	PTFE
12	screw	stainless steel
13	o-ring	EPDM
14	spacer ring	stainless steel
15	grab ring	stainless steel
16	Visu-Control® ring	polypropylene
17	press end with union connection	carbon steel zinc nickel plated
18	split ring	stainless steel
19	union nut	carbon steel zinc nickel plated
20	union sealing washer	EPDM
21	union end adaptor	carbon steel zinc nickel plated

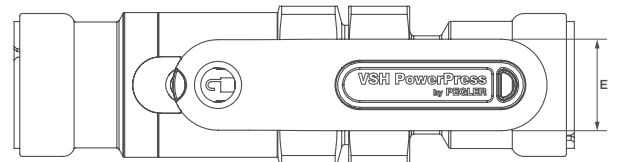
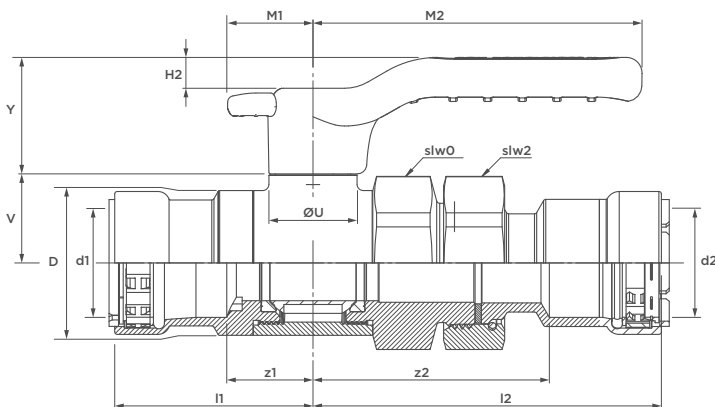

dimension	article no.	weight [kg]	Kvs [m³/h]	l1	z1	l2	z2	slw0	slw2	U	V	Y	H2	E	M1	M2	D
1/2" (DN15)	PWR9440068	0.84	17	55	27	96	68	36	36	28	23	37	10	29	27/34	105	31
3/4" (DN20)	PWR9440079	1.00	41	55	24	102	72	41	41	28	25	37	10	29	27/34	105	38
1" (DN25)	PWR9440081	1.42	70	63	28	111	75	50	50	28	28	37	10	29	27/34	105	46
1 1/4" (DN32)	PWR9440090	1.94	121	80	32	126	76	60	57	28	34	37	10	29	27/34	105	57
1 1/2" (DN40)	PWR9440101	2.73	200	83	35	139	90	70	70	28	41	37	10	29	27/34	165	66
2" (DN50)	PWR9440112	4.14	292	93	40	158	105	85	85	28	48	37	10	29	27/34	165	83

**PPSU550 EL ball valve with extended stem PN16**  
(2 x press, with union connection)



specifications

- maximum pressure 16 bar
- operating temperature -10 to 120°C
- lockable latching with extended stem
- identifiable lock indication
- reversible handle insert (red/blue)
- chrome plated brass full bore ball
- PTFE ball seats

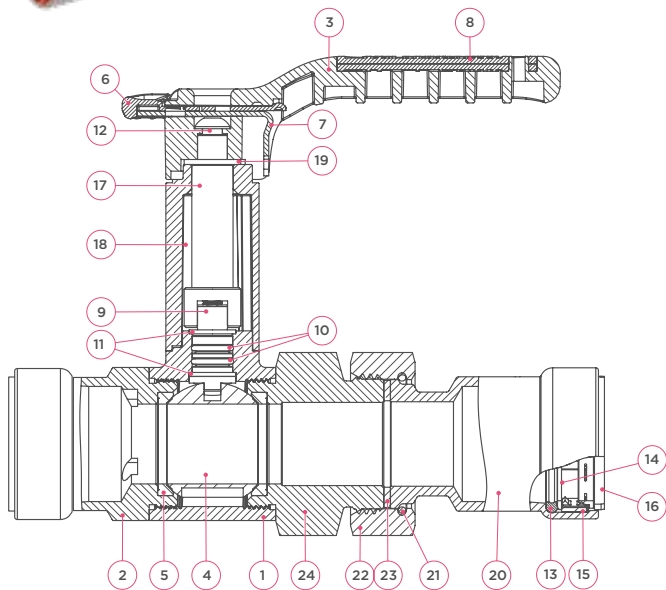

nr.	part	material
1	body	DZR brass (CW511L)
2	press end	carbon steel zinc nickel plated
3	handle	zamak
4	ball	DZR brass (CW511L)
5	seat	PTFE
6	latch grip	nylon 6
7	latch	stainless steel
8	handle insert	TPE
9	spindle	stainless steel
10	spindle seal	EPDM
11	spindle bearing	PTFE
12	screw	stainless steel
13	o-ring	EPDM
14	spacer ring	stainless steel
15	grab ring	stainless steel
16	Visu-Control® ring	polypropylene
17	extended spindle	stainless steel
18	handle extension	zamak
19	handle extensions bearing	PTFE
20	press end with union connection	carbon steel zinc nickel plated
21	split ring	stainless steel
22	union nut	carbon steel zinc nickel plated
23	union sealing washer	EPDM
24	union end adaptor	carbon steel zinc nickel plated

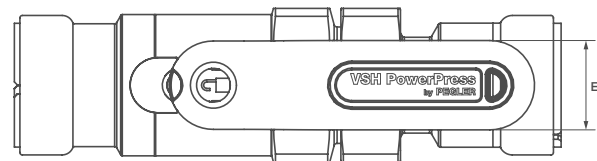
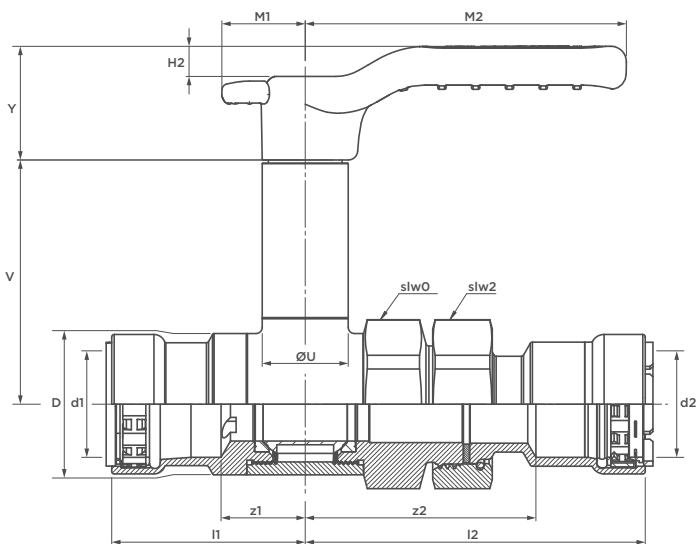

dimension	article no.	weight [kg]	Kvs [m³/h]	I1	I2	z1	z2	slw0	slw2	U	V	H2	Y	E	M1	M2	D
1/2" (DN15)	PWR9440189	0.98	17	55	96	27	68	36	36	28	74	10	37	29	27/34	105	31
3/4" (DN20)	PWR9440191	1.14	41	55	102	24	72	41	41	28	76	10	37	29	27/34	105	38
1" (DN25)	PWR9440200	1.56	70	63	111	28	75	50	50	28	80	10	37	29	27/34	105	46
1 1/4" (DN32)	PWR9440211	2.08	121	80	126	32	78	60	57	28	86	10	37	29	27/34	105	57
1 1/2" (DN40)	PWR9440222	2.87	200	83	139	35	90	70	70	28	92	10	37	29	27/34	105	66
2" (DN50)	PWR9440233	4.28	292	93	158	40	105	85	85	28	99	10	37	29	27/34	105	83

PP1260 static balancing valve  
(2 x press)



specifications

- maximum pressure 16 bar
- operating temperature -10 to 135°C
- fixed orifice (FODRV)
- regulation, isolation and flow measurement
- includes test points
- easy turn grip handle
- handle position indicator
- includes memory stop
- visual press indicators

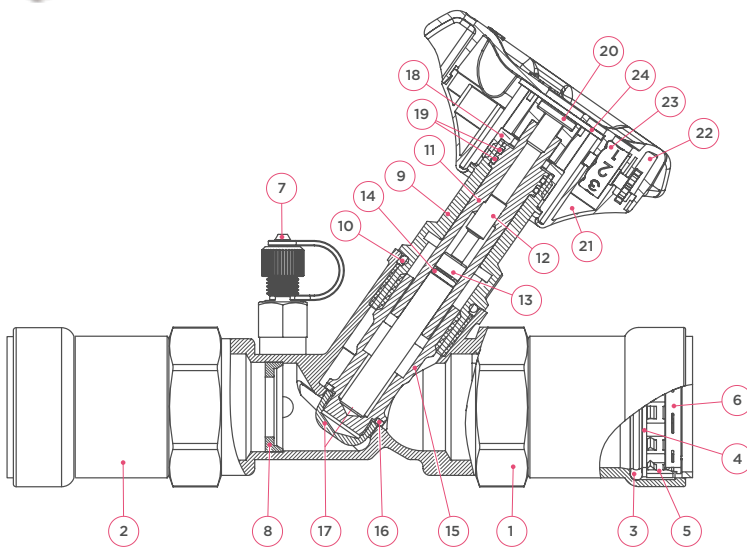

nr.	part	material
1	body	DZR brass
2	press end	carbon steel zinc nickel plated
3	o-ring	EPDM
4	spacer ring	stainless steel
5	grab ring	stainless steel
6	Visu-Control® ring	polypropylene
7	binder point	DZR brass
8	orifice	DZR brass
9	head	DZR brass
10	head seal	EPDM
11	spindle	DZR brass
12	limiting screw	DZR brass
13	limiting pin	DZR brass
14	limiting seal	EPDM
15	valve	DZR brass
16	seat seal	PTFE
17	lower valve	DZR brass
18	spindle retaining nut	DZR brass
19	spindle seal	EPDM
20	screw	DZR brass
21	lower handle	nylon 66
22	upper handle	nylon 66
23	digit register wheel	nylon
24	digit register disc	nylon

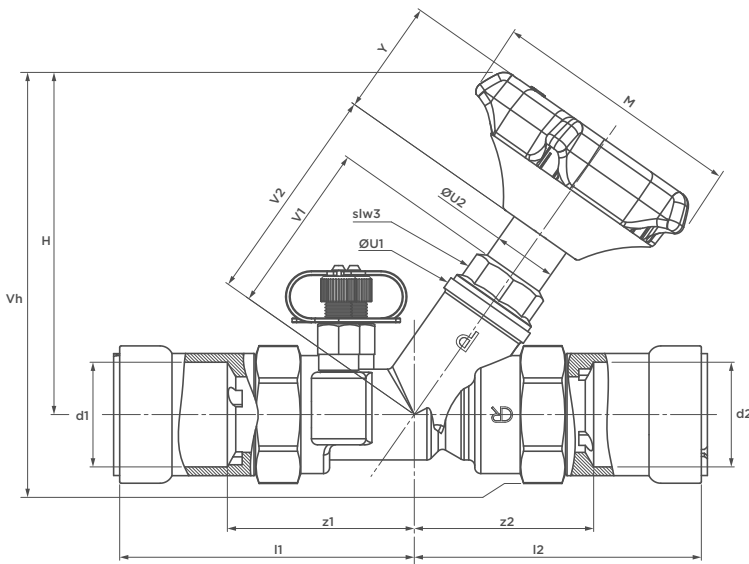

dimension	article no.	weight [kg]	l1	z1	l2	z2	slw3	U1	U2	V1	V2	H	Y	M	Vh
1/2" (DN15) LF	PWR9440486	0.69	76	50	78	50	22	27	20	53	64	106	38	90	122
1/2" (DN15) SF	PWR9440497	0.69	76	50	78	50	22	27	20	53	64	106	38	90	122
3/4" (DN20) SF	PWR9440508	0.80	83	53	83	53	22	27	20	53	64	106	38	90	125
1" (DN25) SF	PWR9440519	1.13	98	62	95	60	25	32	22	57	73	113	38	90	136
1 1/4" (DN32) SF	PWR9440521	1.78	116	68	124	76	32	41	-	64	81	120	38	90	149
1 1/2" (DN40) SF	PWR9440530	2.23	120	71	132	83	35	50	-	66	85	123	38	90	155
2" (DN50) SF	PWR9440541	3.39	137	83	151	98	35	29	-	80	103	138	38	90	178

dimension	Kv [m³/h]	Kvs [m³/h]	flow [l/s]		flow [l/min]		flow [l/h]	
			min.	max.	min.	max.	min.	max.
1/2" (DN15) LF	0,40	0,41	0,01	0,025	0,7	1,5	41	89
1/2" (DN15) SF	1,86	2,15	0,06	0,12	3,6	6,9	216	414
3/4" (DN20) SF	3,36	4,78	0,13	0,21	8,0	12,5	480	750
1" (DN25) SF	6,11	8,11	0,23	0,38	13,5	22,8	810	1368
1 1/4" (DN32) SF	12,65	15,41	0,43	0,79	25,7	47,1	1542	2826
1 1/2" (DN40) SF	19,00	22,23	0,62	1,18	37,1	70,8	2226	4248
2" (DN50) SF	28,42	48,21	1,34	1,77	80,4	105,9	4824	6354

flow rate

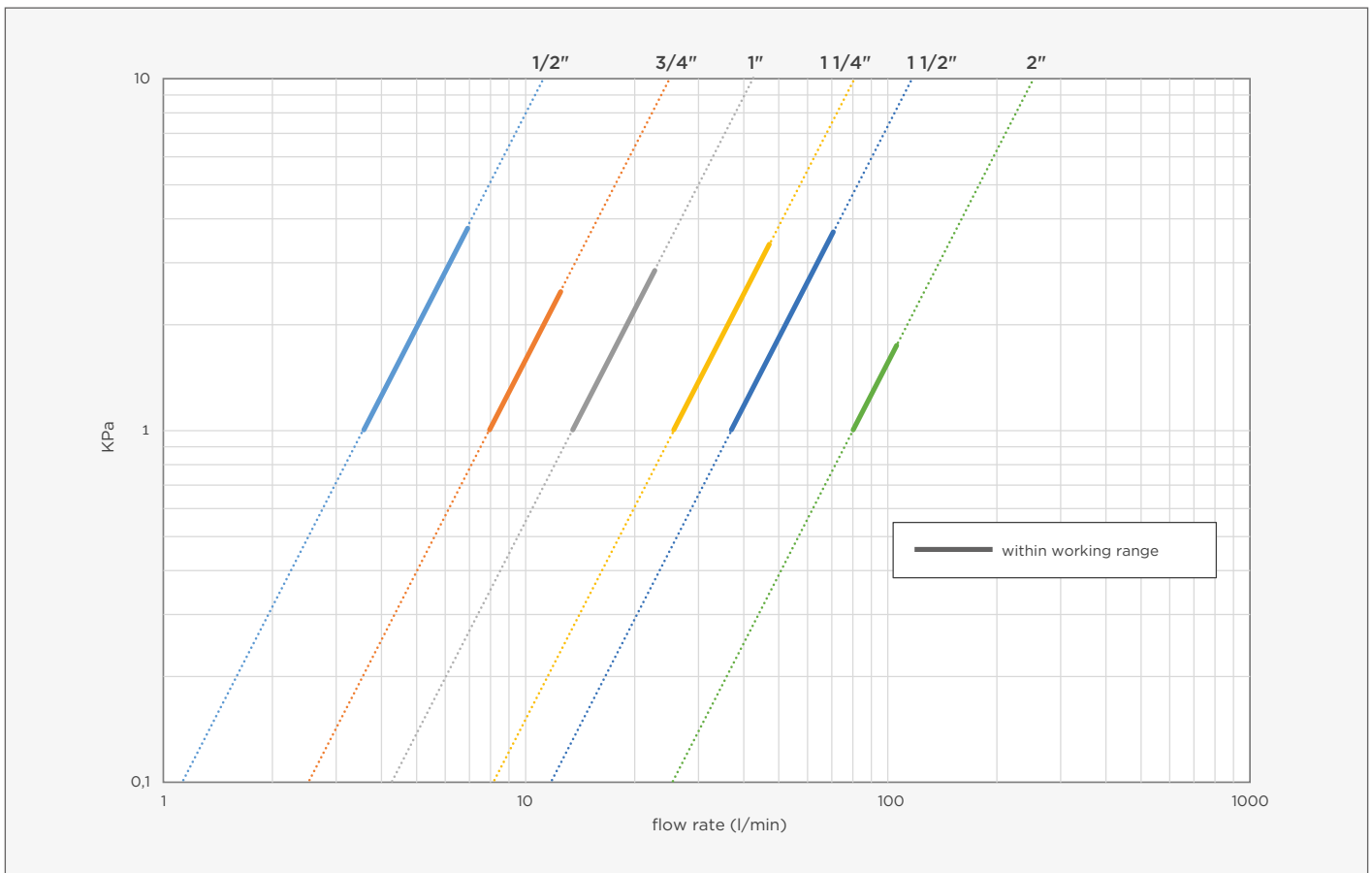

pressure loss



**PPSU1260 static balancing valve PN16**  
(2 x press, with union connection)



specifications

- maximum pressure 16 bar
- operating temperature -10 to 120°C
- fixed orifice (FODRV)
- regulation, isolation and flow measurement
- includes test points
- easy turn grip handle
- handle position indicator
- includes memory stop

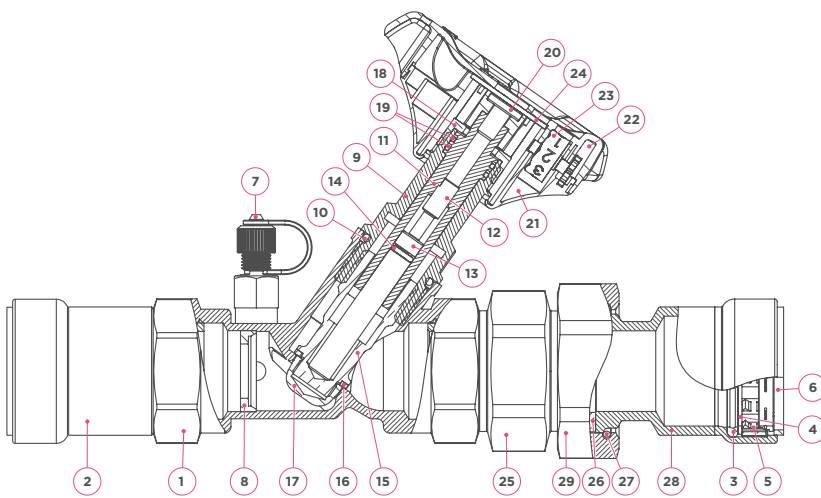

nr.	part	material
1	body	DZR brass
2	adapter	carbon steel zinc nickel plated
3	o-ring	EPDM
4	spacer ring	stainless steel
5	grab ring	stainless steel
6	Visu-Control® ring	polypropylene
7	binder point	DZR brass
8	orifice	DZR brass
9	head	DZR brass
10	head seal	EPDM
11	spindle	DZR brass
12	limiting screw	DZR brass
13	limiting pin	DZR brass
14	limiting seal	EPDM
15	valve	DZR brass
16	seat seal	PTFE
17	lower valve	DZR brass
18	spindle retaining nut	DZR brass
19	spindle seal	EPDM
20	screw	DZR brass
21	lower handle	nylon 66
22	upper handle	nylon 66
23	digit register wheel	nylon
24	digit register disc	nylon
25	union end adaptor	carbon steel zinc nickel plated
26	flat face washer	EPDM
27	split ring	stainless steel
28	union end	carbon steel zinc nickel plated
29	union nut	carbon steel zinc nickel plated

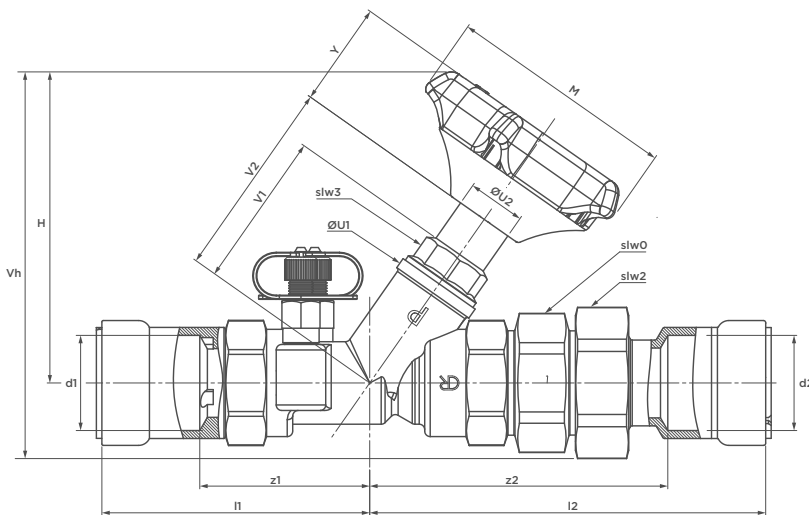

dimension	article no.	weight [kg]	l1	z1	l2	z2	slw0	slw2	slw3	U1	U2	V1	V2	H	Y	M	Vh
1/2" (DN15) LF	PWR9440552	0.90	78	50	120	92	27	36	22	27	20	53	64	106	38	90	126
1/2" (DN15) SF	PWR9440563	0.90	78	50	120	92	27	36	22	27	20	53	64	106	38	90	126
3/4" (DN20) SF	PWR9440574	1.10	83	53	132	102	32	41	22	27	20	53	64	106	38	90	128
1" (DN25) SF	PWR9440585	1.63	98	62	144	109	46	50	25	32	22	57	73	113	38	90	141
1 1/4" (DN32) SF	PWR9440596	2.37	116	68	174	126	50	57	32	41	-	64	81	120	38	90	151
1 1/2" (DN40) SF	PWR9440607	3.10	120	71	187	138	60	70	35	50	-	66	85	123	38	90	162
2" (DN50) SF	PWR9440618	4.80	137	83	219	165	75	85	35	29	-	80	103	138	38	90	185

dimension	Kv [m³/h]	Kvs [m³/h]	flow [l/s]		flow [l/min]		flow [l/h]	
			min.	max.	min.	max.	min.	max.
1/2" (DN15) LF	0,40	0,41	0,01	0,025	0,7	1,5	41	89
1/2" (DN15) SF	1,86	2,15	0,06	0,12	3,6	6,9	216	414
3/4" (DN20) SF	3,36	4,78	0,13	0,21	8,0	12,5	480	750
1" (DN25) SF	6,11	8,11	0,23	0,38	13,5	22,8	810	1368
1 1/4" (DN32) SF	12,65	15,41	0,43	0,79	25,7	47,1	1542	2826
1 1/2" (DN40) SF	19,00	22,23	0,62	1,18	37,1	70,8	2226	4248
2" (DN50) SF	28,42	48,21	1,34	1,77	80,4	105,9	4824	6354

flow rate

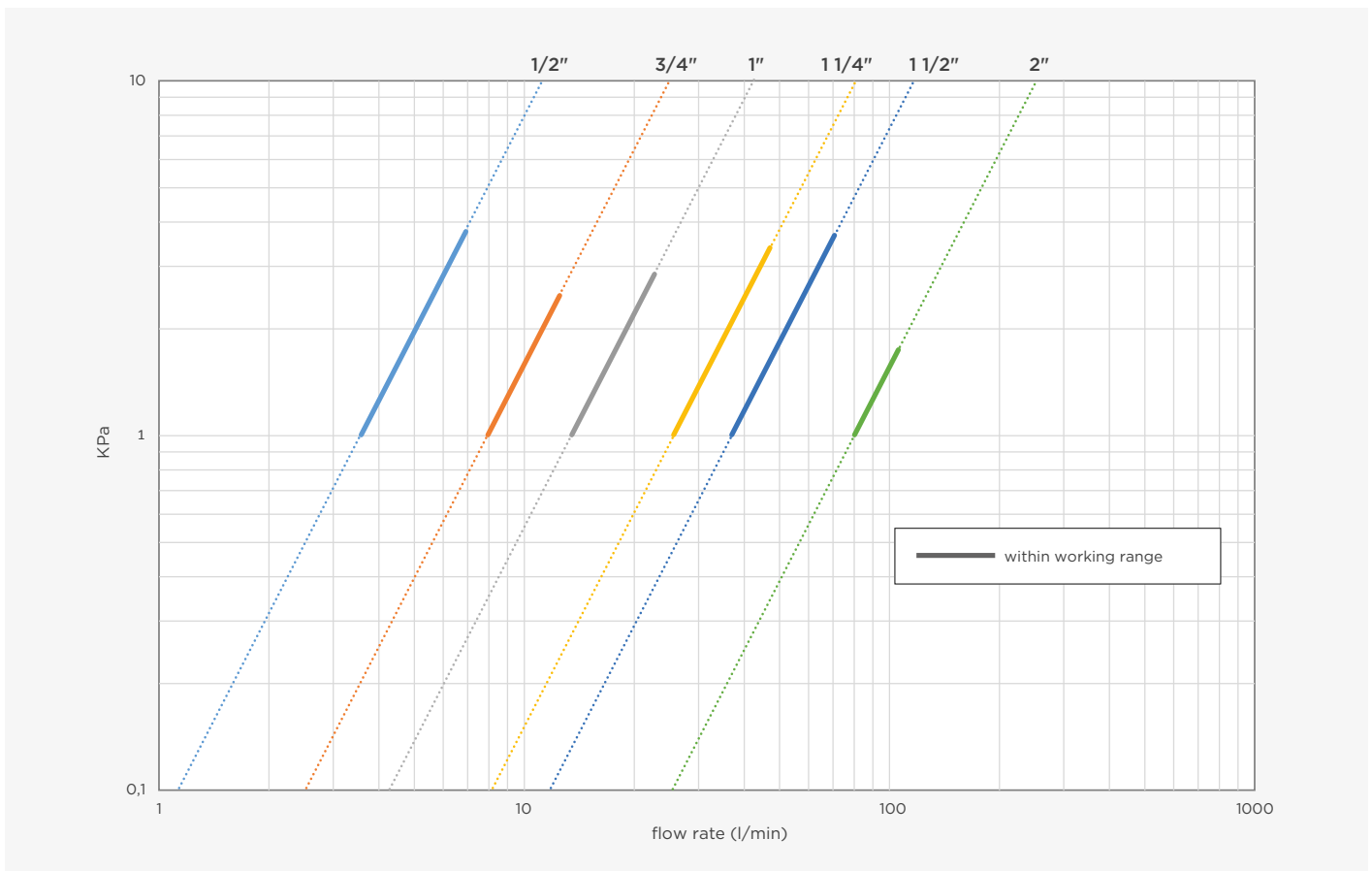

pressure loss

PP900 static balancing valve  
(2 x press)



specifications

- maximum pressure 16 bar
- operating temperature -20 to 120°C
- venturi nozzle with fixed Kvm values
- regulation, isolation and flow measurement
- precise and easy to read scale settings
- no change in settings when isolated
- easy identification of open or isolated position

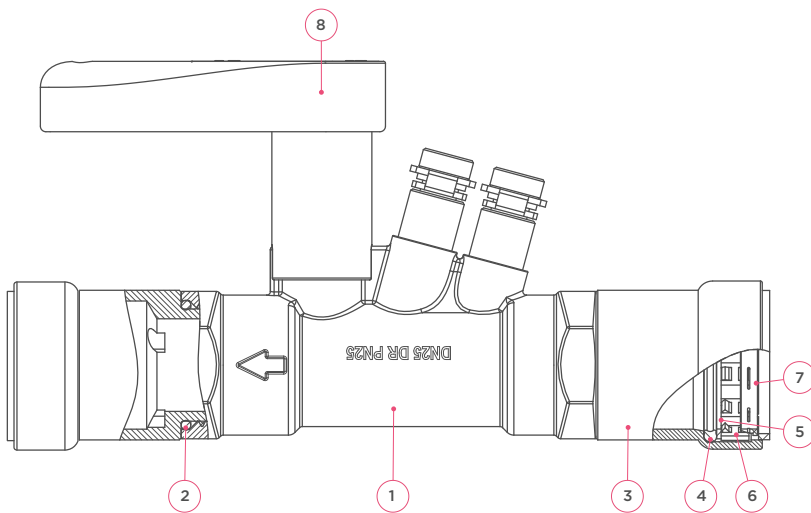

nr.	part	material
1	body	DZR brass (CW602N)
2	o-ring	EPDM
3	press end	carbon steel zinc nickel plated
4	o-ring	EPDM
5	spacer ring	stainless steel
6	grab ring	stainless steel
7	Visu-Control® ring	polypropylene
8	handle	polyamide

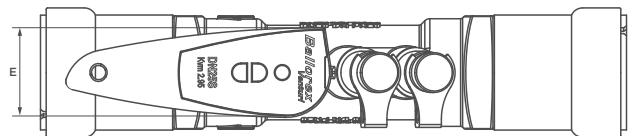
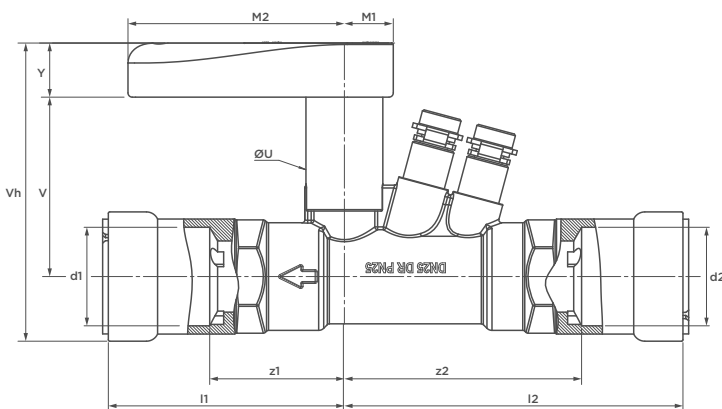

dimension	article no.	weight [kg]	l1	z1	l2	z2	U	V	Y	H	M1	M2	E	Vh	VI
1/2" (DN15) LF	PWR94440629	0.59	67	39	103	75	27	56	19	75	17	76	32	91	170
1/2" (DN15) SF	PWR94440631	0.59	67	39	103	75	27	56	19	75	17	76	32	91	170
3/4" (DN20) SF	PWR94440640	0.74	71	41	109	79	27	59	19	78	17	76	32	97	180
1" (DN25) SF	PWR94440651	1.02	83	48	119	84	27	63	19	82	17	76	32	105	202
1 1/4" (DN32) HF	PWR94440662	1.87	105	57	145	97	43	81	30	110	23	123	45	138	250
1 1/2" (DN40) HF	PWR94440673	2.32	112	63	154	105	43	81	30	110	23	123	45	141	265
2" (DN50) HF	PWR94440684	3.33	121	68	163	110	43	91	30	120	23	123	45	157	285

dimension	Kvs [m³/h]	Kvm [m³/h]	flow [l/s]		flow [l/min]		flow [l/h]	
			min.	max.	min.	max.	min.	max.
1/2" (DN15) LF	0,629	0,359	0,0172	0,074	1,032	4,44	61,9	266,4
1/2" (DN15) SF	1,62	0,746	0,036	0,148	2,160	8,88	129,6	532,8
3/4" (DN20) SF	2,82	1,56	0,074	0,325	4,440	19,50	266,4	1170,0
1" (DN25) SF	7,54	2,95	0,142	0,603	8,52	36,18	511,2	2170,8
1 1/4" (DN32) HF	13,2	6,01	0,290	1,250	17,40	75,00	1044,0	4500,0
1 1/2" (DN40) HF	22	9,2	0,440	1,880	26,40	112,80	1584,0	6768,0
2" (DN50) HF	36	17,1	0,820	3,510	49,20	210,60	2952,0	12636,0

flow rate

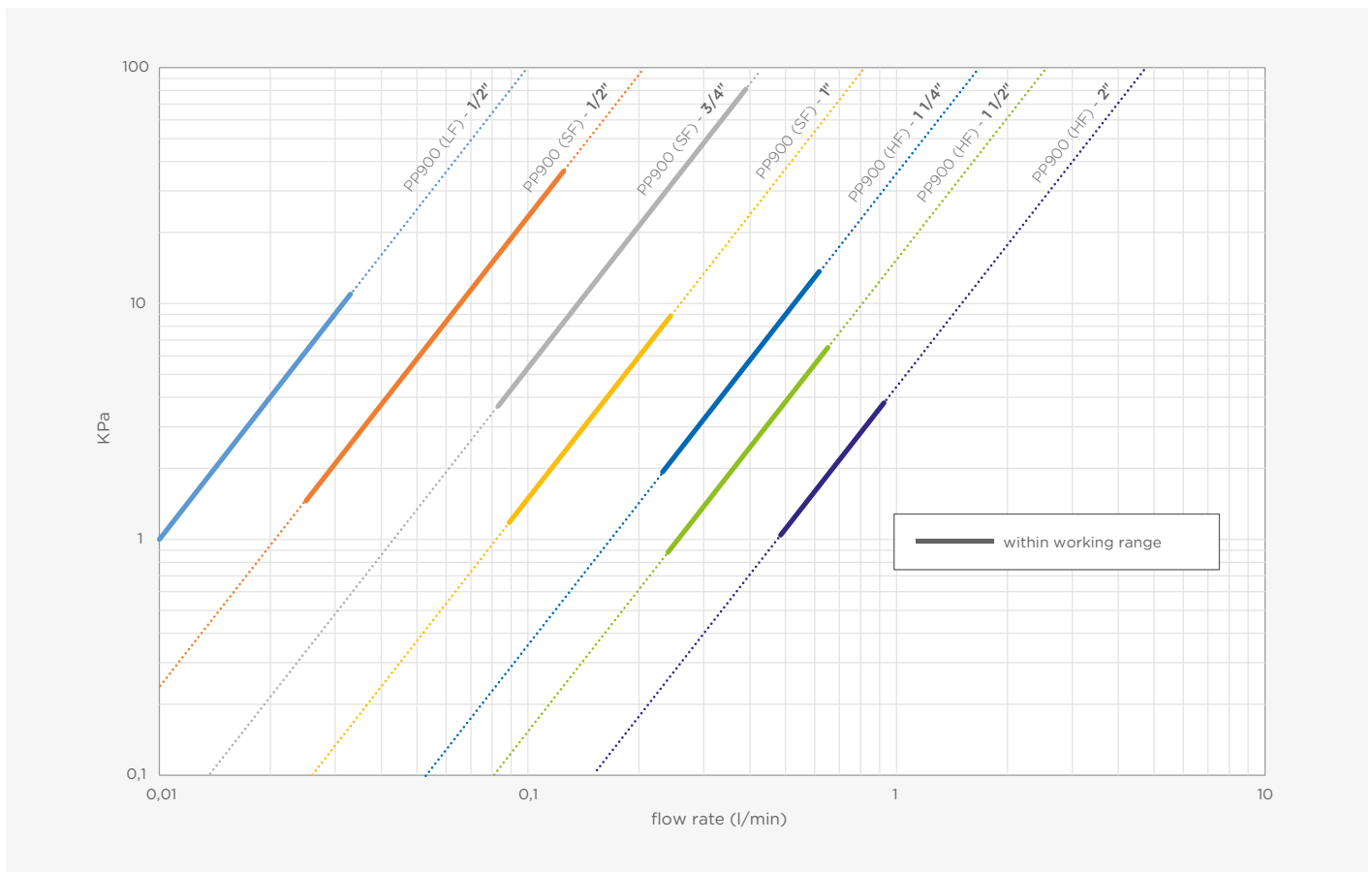

pressure loss

## PPSU900 static balancing valve PN16

(2 x press, with union connection)



### specifications

- maximum pressure 16 bar
- operating temperature -20 to 120°C
- venturi nozzle with fixed Kvm values
- regulation, isolation and flow measurement
- precise and easy to read scale settings
- no change in settings when isolated
- easy identification of open or isolated position

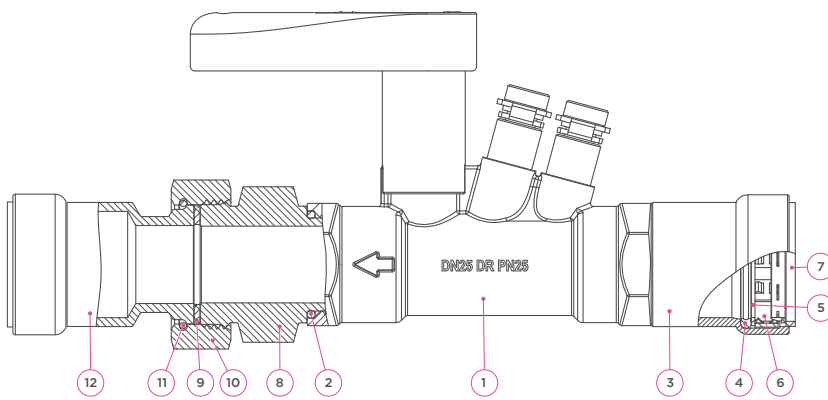

nr.	part	material
1	body	DZR brass CW602N
2	o-ring	EPDM
3	press end	carbon steel zinc nickel plated
4	o-ring	EPDM
5	spacer ring	stainless steel
6	grab ring	stainless steel
7	Visu-Control® ring	polypropylene
8	union end adaptor	carbon steel zinc nickel plated
9	flat face washer	EPDM
10	union nut	carbon steel zinc nickel plated
11	split ring	stainless steel
12	union end	carbon steel zinc nickel plated

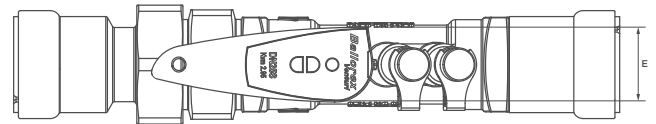
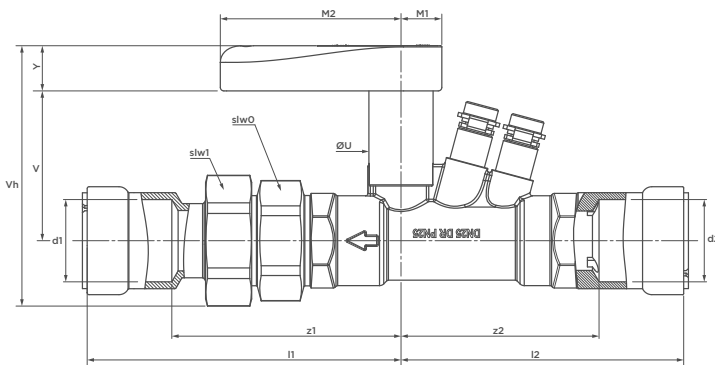

dimension	article no.	weight [kg]	l1	z1	l2	z2	U	V	Y	slw0	slw1	M1	M2	E	Vh
1/2" (DN15) LF	PWR9440695	0.80	110	82	103	75	27	56	19	27	36	17	76	32	95
1/2" (DN15) SF	PWR9440706	0.80	110	82	103	75	27	56	19	27	36	17	76	32	95
3/4" (DN20) SF	PWR9440717	1.04	120	90	109	79	27	59	19	36	41	17	76	32	101
1" (DN25) SF	PWR9440728	1.52	132	97	119	84	27	63	19	46	50	17	76	32	110
1 1/4" (DN32) HF	PWR9440739	2.46	154	106	145	97	43	81	30	50	57	23	123	45	142
1 1/2" (DN40) HF	PWR9440741	3.18	167	118	154	105	43	81	30	60	70	23	123	45	149
2" (DN50) HF	PWR9440750	4.74	189	136	163	110	43	91	30	75	85	23	123	45	167



dimension	Kvs [m³/h]	Kvm	flow [l/s]		flow [l/min]		flow [l/h]	
			min.	max.	min.	max.	min.	max.
1/2" (DN15) LF	0,629	0,359	0,0172	0,074	1,032	4,44	61,9	266,4
1/2" (DN15) SF	1,62	0,746	0,036	0,148	2,160	8,88	129,6	532,8
3/4" (DN20) SF	2,82	1,56	0,074	0,325	4,440	19,50	266,4	1170,0
1" (DN25) SF	7,54	2,95	0,142	0,603	8,52	36,18	511,2	2170,8
1 1/4" (DN32) HF	13,2	6,01	0,290	1,250	17,40	75,00	1044,0	4500,0
1 1/2" (DN40) HF	22	9,2	0,440	1,880	26,40	112,80	1584,0	6768,0
2" (DN50) HF	36	17,1	0,820	3,510	49,20	210,60	2952,0	12636,0

flow rate

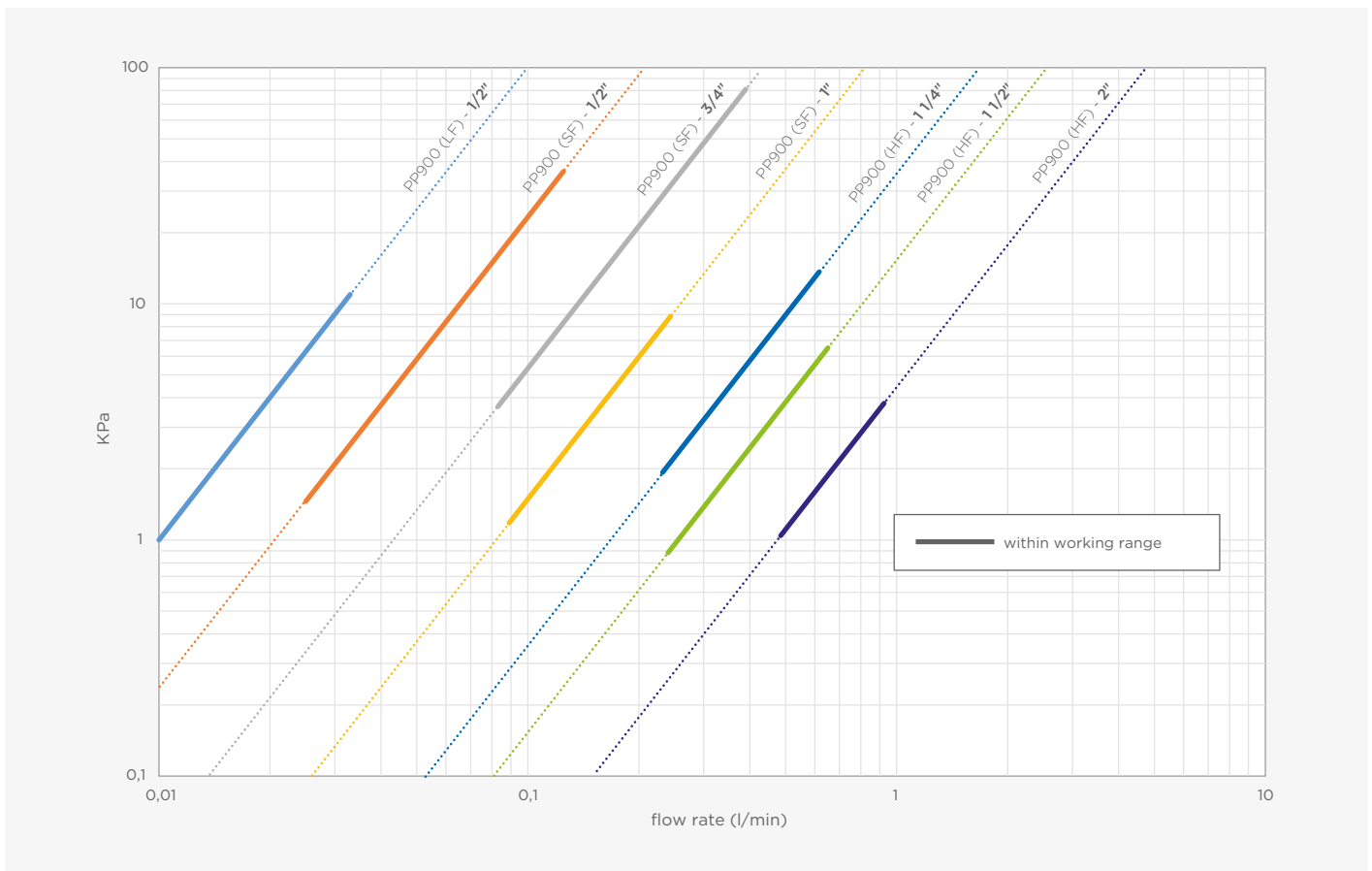

pressure loss

PP902 dynamic balancing valve PN16  
(2 x press)



specifications

- maximum pressure 16 bar
- operating temperature -20 to 120°C
- automatic balancing
- direct flow measuring of actual flow
- high flow accuracy
- easy system flushing due to removable cartridge

nr.	part	material
1	body	DZR brass
2	o-ring	EPDM
3	press end	carbon steel zinc nickel plated
4	o-ring	EPDM
5	spacer ring	stainless steel
6	grab ring	stainless steel
7	Visu-Control® ring	polypropylene

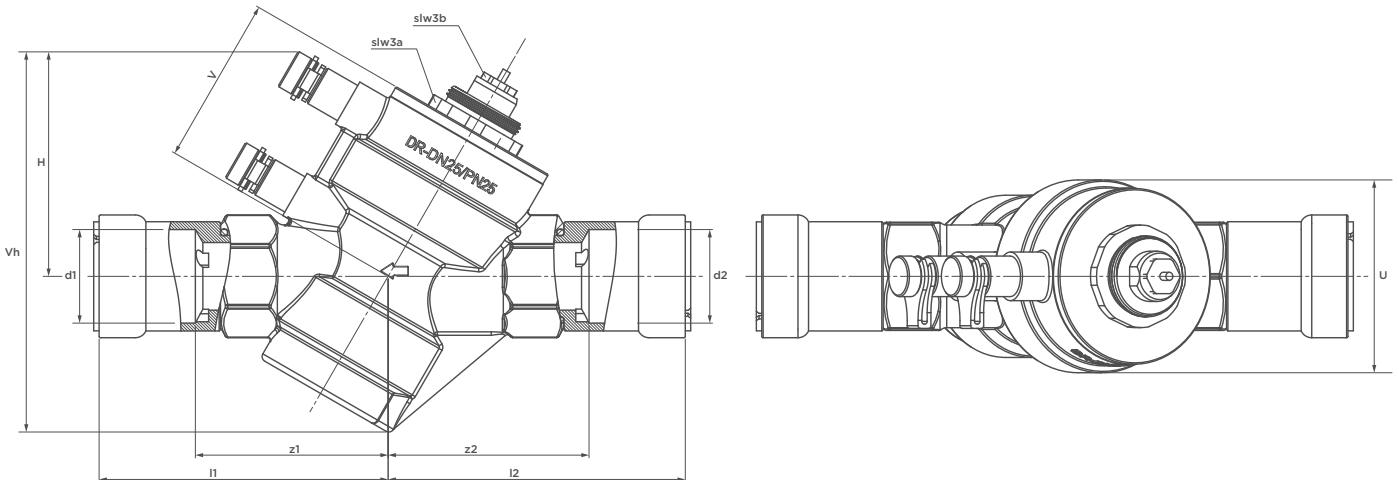
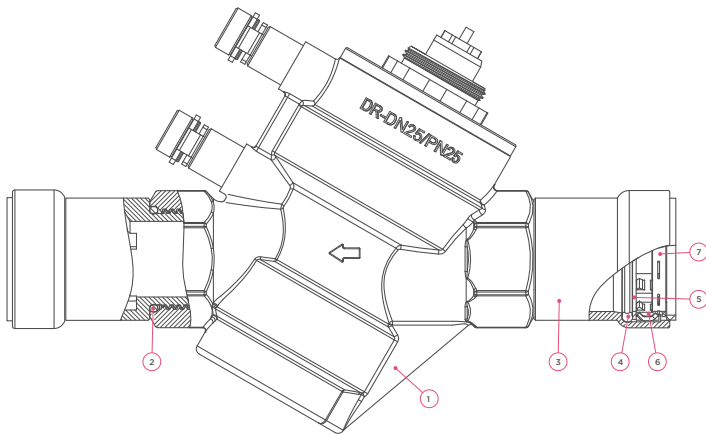

dimension	article no.	weight [kg]	l1	z1	l2	z2	U	V	H	slw3a	slw3b	Vh
1/2" (DN15) LF	PWR9440761	0.73	84	56	87	59	43	51	74	37	13	111
1/2" (DN15) SF	PWR9440772	0.72	84	56	87	59	43	51	74	37	13	111
1/2" (DN15) HF	PWR9440783	0.71	84	56	87	59	43	51	74	37	13	111
3/4" (DN20) SF	PWR9440794	1.08	104	74	96	66	54	57	78	37	13	127
3/4" (DN20) HF	PWR9440805	1.08	104	74	96	66	54	57	78	37	13	127
1" (DN25) SF	PWR9440816	1.64	107	72	110	75	71	62	83	37	13	141
1" (DN25) HF	PWR9440827	1.64	107	72	110	75	71	62	83	37	13	141
1 1/4" (DN32) HF	PWR9440838	2.33	136	88	138	90	81	64	88	37	13	166
1 1/2" (DN40) HF	PWR9440849	4.29	158	109	158	109	110	91	121	37	13	210
2" (DN50) HF	PWR9440851	4.64	160	106	165	111	110	94	123	37	13	209

dimension	Kvm [m³/h]	flow [l/s]		flow [l/min]		flow [l/h]	
		min.	max.	min.	max.	min.	max.
1/2" (DN15) LF	0,23	0,010	0,033	0,60	1,98	36,0	118,80
1/2" (DN15) SF	0,78	0,025	0,125	1,50	7,50	90,0	450,00
1/2" (DN15) HF	2,50	0,083	0,390	4,98	23,40	298,8	1404,00
3/4" (DN20) SF	1,90	0,089	0,245	5,34	14,70	320,4	882,00
3/4" (DN20) HF	4,70	0,232	0,617	13,92	37,02	835,2	2221,20
1" (DN25) SF	5,05	0,240	0,650	14,40	39,00	864,0	2340,00
1" (DN25) HF	8,25	0,485	0,925	29,10	55,50	1746,0	3330,00
1 1/4" (DN32) HF	8,35	0,530	1,220	31,80	73,20	1908,0	4392,00
1 1/2" (DN40) HF	17,50	1,020	2,100	61,20	126,00	3672,0	7560,00
2" (DN50) HF	29,50	1,440	3,500	86,40	210,00	5184,0	12600,00

flow rate

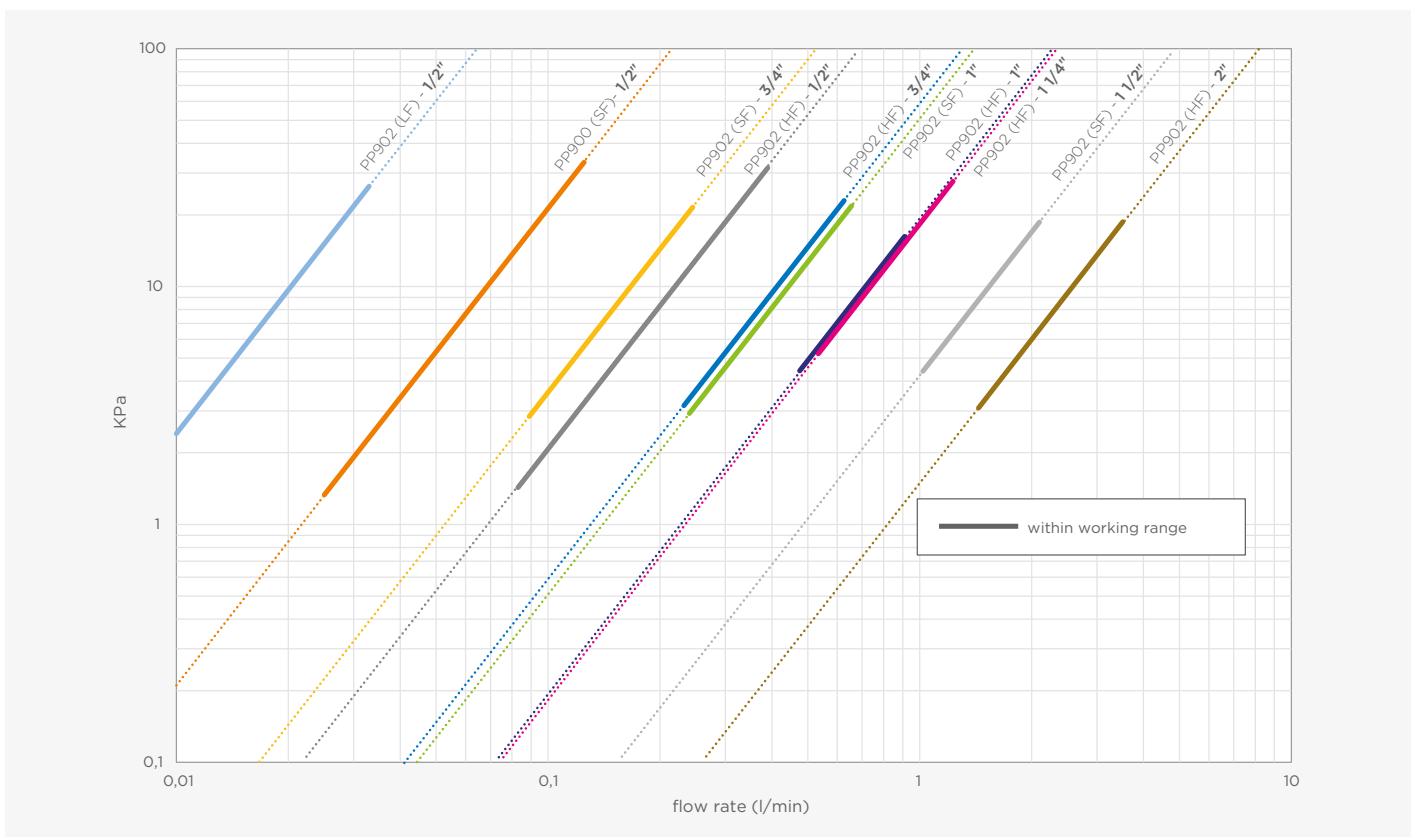

pressure loss

### B6625 electro-thermal actuator (for DN15-25)



art. no.	description	Vb	VI	H1	d1	a
6402101	on/off-actuator 24V	44	48	52	M30	7
6402110	on/off-actuator 230V	44	48	52	M30	7
6402121	modulating actuator 24V (0-10V)	44	48	52	M30	7

### B6659 electro-mechanical actuator (for DN15-32)

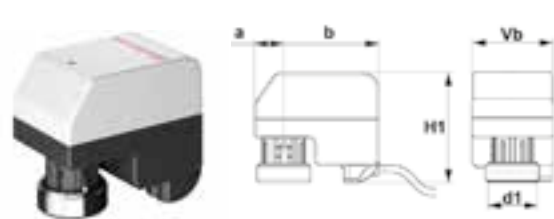

art. no.	description	Vb	H1	d1	a	b
6402847	on/off-actuator 24V	50	68	M30	17	60
6402143	on/off-actuator 230V	50	68	M30	17	60
6402858	modulating actuator 24V (0-10V)	50	68	M30	17	60

**PPSU902 dynamic balancing valve PN16**  
(2 x press, with union connection)



**specifications**

- maximum pressure 16 bar
- operating temperature -20 to 120°C
- automatic balancing
- direct flow measuring of actual flow
- high flow accuracy
- easy system flushing due to removable cartridge

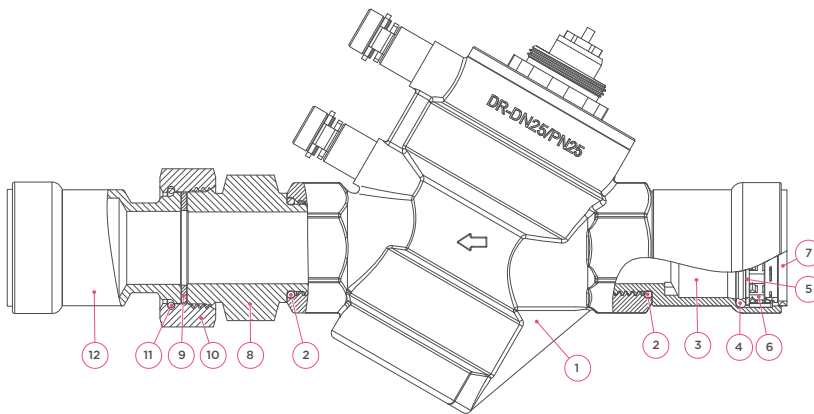

nr.	part	material
1	body	DZR brass
2	o-ring	EPDM
3	adapter	carbon steel zinc nickel plated
4	o-ring	EPDM
5	spacer ring	stainless steel
6	grab ring	stainless steel
7	Visu-Control® ring	polypropylene
8	union end adaptor	carbon steel zinc nickel plated
9	flat face washer	EPDM
10	union nut	carbon steel zinc nickel plated
11	split ring	stainless steel
12	union end	carbon steel zinc nickel plated

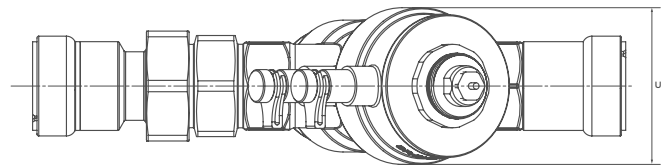
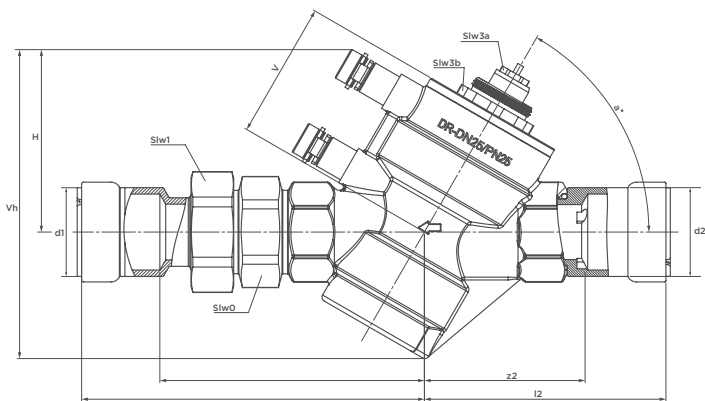

dimension	article no.	weight [kg]	l1	l2	z1	z2	D	U	a°	V	H	slw0	slw1	slw3a	slw3b	Vh
1/2" (DN15) LF	PWR9440860	0.94	127	87	99	59	28	43	60	51	74	27	36	37	13	111
1/2" (DN15) SF	PWR9440871	0.93	127	87	99	59	28	43	60	51	74	27	36	37	13	111
1/2" (DN15) HF	PWR9440882	0.92	127	87	99	59	28	43	60	51	74	27	36	37	13	111
3/4" (DN20) SF	PWR9440893	1.38	153	96	123	66	33	54	45	57	78	36	41	37	13	127
3/4" (DN20) HF	PWR9440904	1.38	153	96	123	66	33	54	45	57	78	36	41	37	13	127
1" (DN25) SF	PWR9440915	2.14	152	110	117	75	40	71	60	62	83	46	50	37	13	141
1" (DN25) HF	PWR9440926	2.14	152	110	117	75	40	71	60	62	83	46	50	37	13	141
1 1/4" (DN32) HF	PWR9440937	2.92	185	138	137	90	49	81	60	64	88	50	57	37	13	166
1 1/2" (DN40) SF	PWR9440948	5.16	213	158	164	109	56	110	60	91	121	60	70	37	13	210
2" (DN50) HF	PWR9440959	6.05	227	165	174	111	68	110	60	94	123	75	85	37	13	209

dimension	Kvm [m³/h]	flow [l/s]		flow [l/min]		flow [l/h]	
		min.	max.	min.	max.	min.	max.
1/2" (DN15) LF	0,23	0,010	0,033	0,60	1,98	36,0	118,80
1/2" (DN15) SF	0,78	0,025	0,125	1,50	7,50	90,0	450,00
1/2" (DN15) HF	2,50	0,083	0,390	4,98	23,40	298,8	1404,00
3/4" (DN20) SF	1,90	0,089	0,245	5,34	14,70	320,4	882,00
3/4" (DN20) HF	4,70	0,232	0,617	13,92	37,02	835,2	2221,20
1" (DN25) SF	5,05	0,240	0,650	14,40	39,00	864,0	2340,00
1" (DN25) HF	8,25	0,485	0,925	29,10	55,50	1746,0	3330,00
1 1/4" (DN32) HF	8,35	0,530	1,220	31,80	73,20	1908,0	4392,00
1 1/2" (DN40) SF	17,50	1,020	2,100	61,20	126,00	3672,0	7560,00
2" (DN50) HF	29,50	1,440	3,500	86,40	210,00	5184,0	12600,00

flow rate

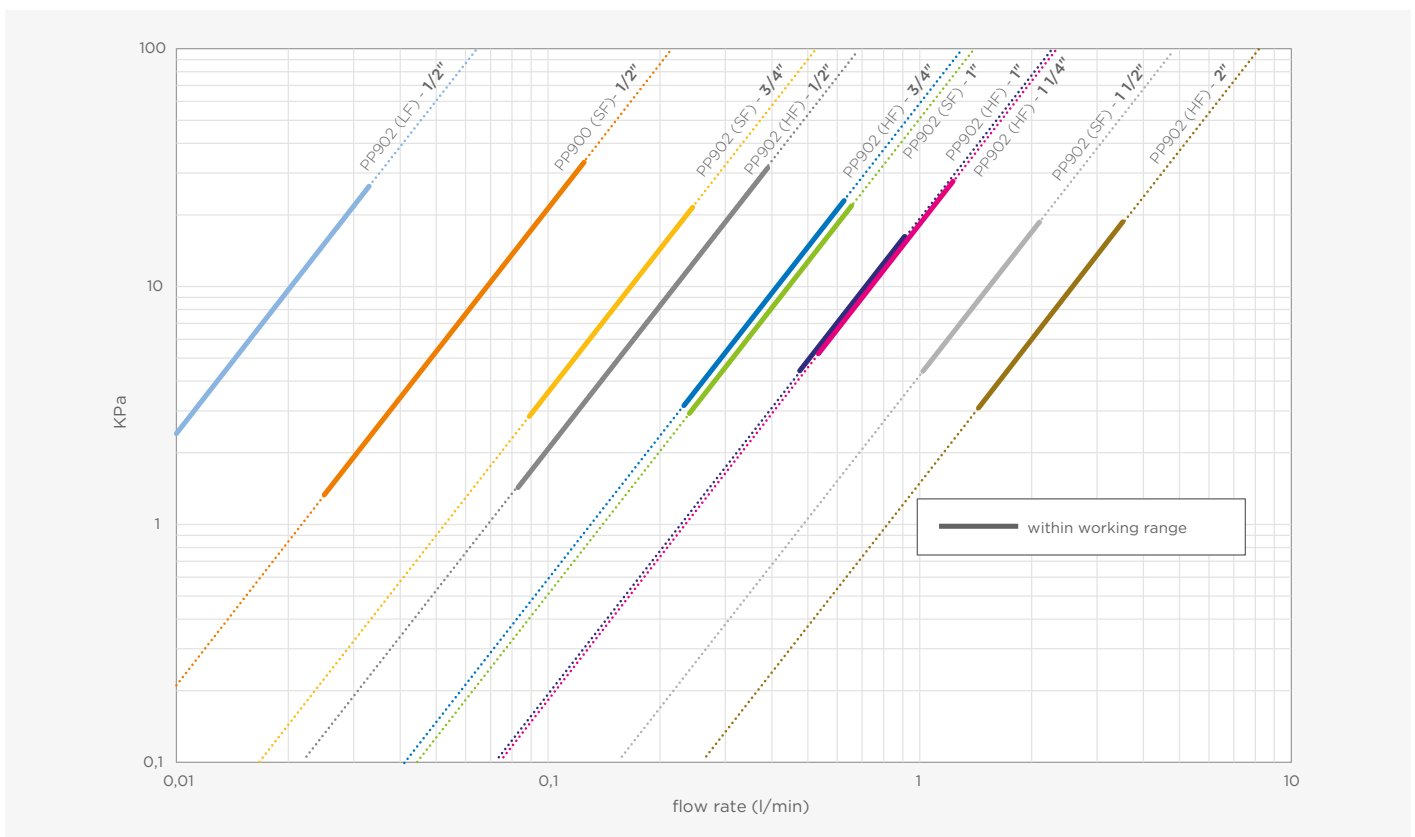

pressure loss

### B6625 electro-thermal actuator (for DN15-25)



art. no.	description	Vb	V1	H1	d1	a
6402101	on/off-actuator 24V	44	48	52	M30	7
6402110	on/off-actuator 230V	44	48	52	M30	7
6402121	modulating actuator 24V (0-10V)	44	48	52	M30	7

### B6659 electro-mechanical actuator (for DN15-32)

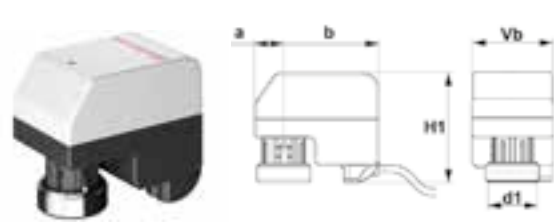

art. no.	description	Vb	H1	d1	a	b
6402847	on/off-actuator 24V	50	68	M30	17	60
6402143	on/off-actuator 230V	50	68	M30	17	60
6402858	modulating actuator 24V (0-10V)	50	68	M30	17	60

PP1070/125 gate valve PN16  
(2 x press)



specifications

- maximum pressure 16 bar
- operating temperature -10 to 110°C
- solid gunmetal wedge
- non rising stem
- gland packed

nr.	part	material
1	body	gunmetal
2	adapter	carbon steel zinc nickel plated
3	o-ring	EPDM
4	spacer ring	stainless steel
5	grab ring	stainless steel
6	Visu-Control® ring	stainless steel

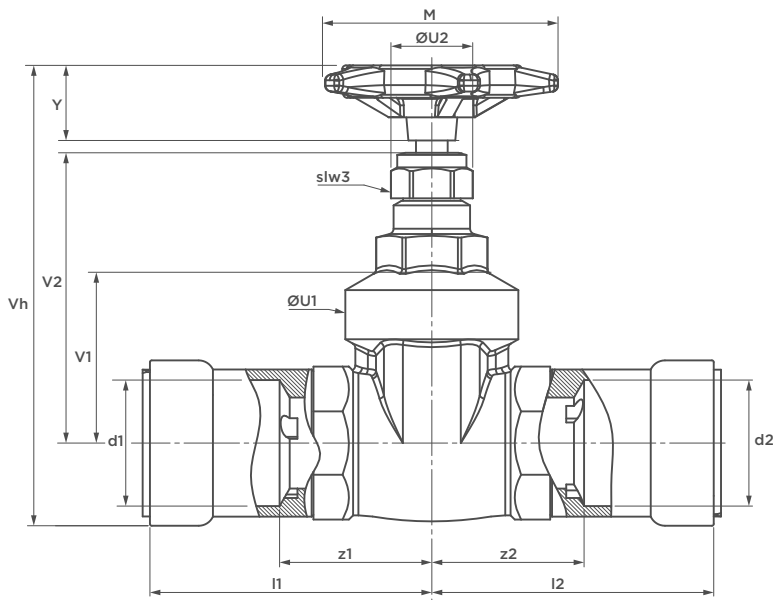
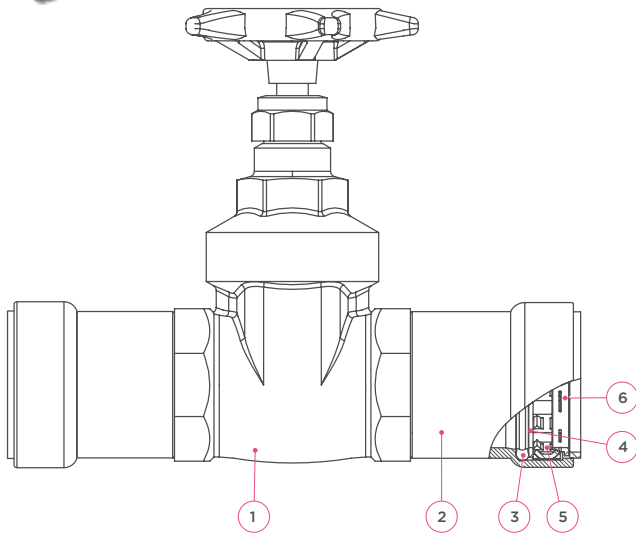

dimension	article no.	weight [kg]	Kvs [m³/h]	l1/l2	z1/z2	U1	U2	V1	V2	Y	slw3	M	Vh
1/2" (DN15)	PWR9440365	0.48	14	64	36	33	23	32	58	17	20	60	100
3/4" (DN20)	PWR9440376	0.68	32	68	38	40	23	39	68	18	20	60	113
1" (DN25)	PWR9440387	1.01	57	78	42	48	23	47	80	21	20	70	126
1 1/4" (DN32)	PWR9440398	1.57	90	96	48	56	28	56	92	21	25	75	147
1 1/2" (DN40)	PWR9440409	2.07	129	100	52	65	28	65	109	26	25	95	178
2" (DN50)	PWR9440411	3.08	230	109	56	81	33	87	130	29	29	104	203



PPSU1070/125 gate valve PN16  
(2 x press, with union connection)



specifications

- maximum pressure 16 bar
- operating temperature -10 to 110°C
- solid gunmetal wedge
- non rising stem
- gland packed

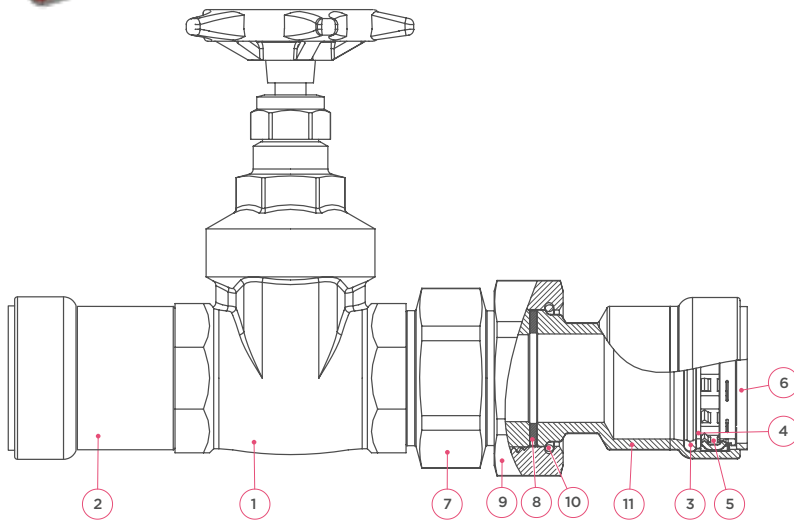

nr.	part	material
1	body	gunmetal
2	adapter	carbon steel zinc nickel plated
3	o-ring	EPDM
4	spacer ring	stainless steel
5	grab ring	stainless steel
6	Visu-Control® ring	stainless steel
7	union end adaptor	carbon steel zinc nickel plated
8	flat face washer	EPDM
9	union nut	carbon steel zinc nickel plated
10	split ring	stainless steel
11	union end	carbon steel zinc nickel plated

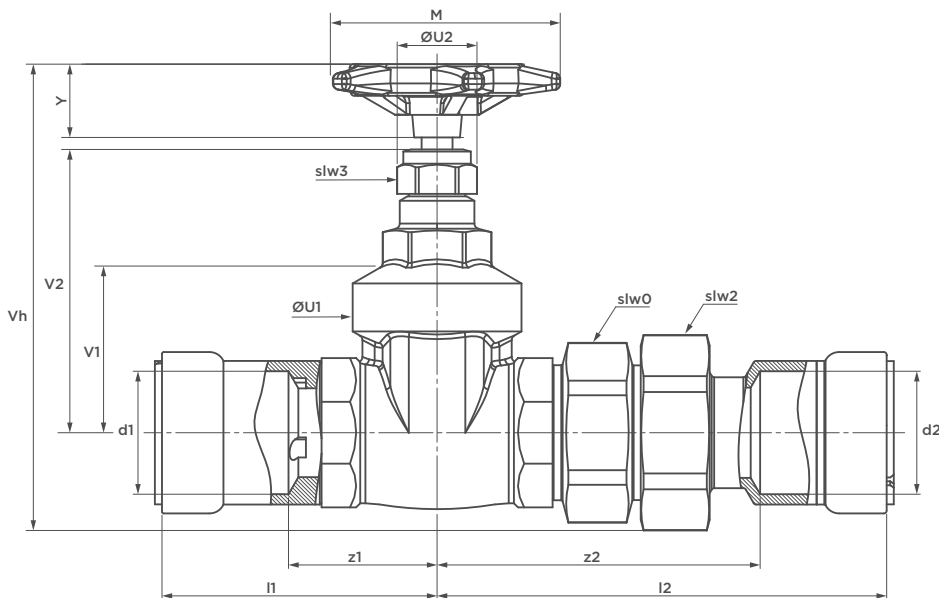

dimension	article no.	weight [kg]	Kvs [m³/h]	l1	z1	l2	z2	U1	U2	V1	V2	Y	slw0	slw2	slw3	M	Vh
1/2" (DN15)	PWR9440420	0.69	14	64	36	107	79	33	23	32	58	17	27	36	20	60	103
3/4" (DN20)	PWR9440431	0.98	32	68	38	117	87	40	23	39	68	18	32	41	23	60	117
1" (DN25)	PWR9440442	1.51	57	78	42	127	91	48	23	47	80	21	46	50	27	70	131
1 1/4" (DN32)	PWR9440453	2.16	90	96	48	146	98	56	28	56	92	21	50	57	30	75	151
1 1/2" (DN40)	PWR9440464	2.94	129	100	52	156	107	66	28	65	109	26	60	70	32	95	185
2" (DN50)	PWR9440475	4.49	230	109	56	177	124	81	33	87	130	29	75	85	40	104	213

PP913 y-strainer PN16  
(2 x press)



specifications

- maximum pressure 16 bar
- operating temperature -10 to 120°C
- high effective protection from system debris
- y pattern
- stainless steel mesh (0.92 mm)

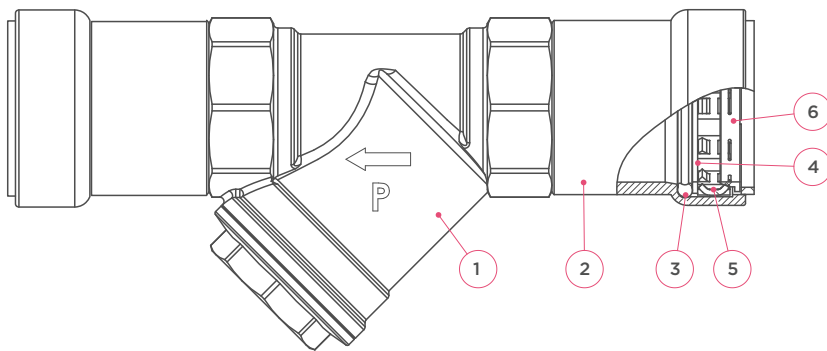

nr	part	material
1	body	gunmetal
2	press end	carbon steel zinc nickel plated
3	o-ring	EPDM
4	spacer ring	stainless steel
5	grab ring	stainless steel
6	Visu-Control® ring	polypropylene

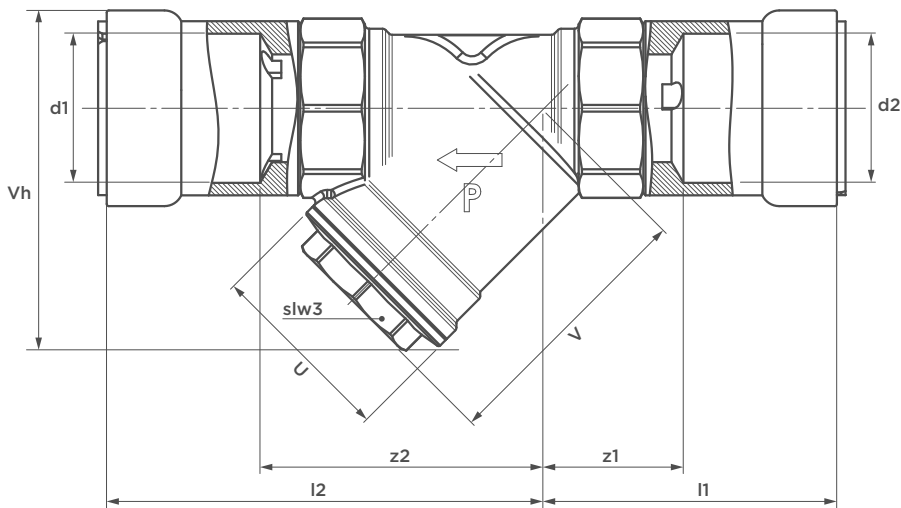

dimension	article no.	weight [kg]	l1	l2	z1	z2	U	V	H	slw3	Vh
1/2" (DN15)	PWR9440961	0.59	59	80	31	52	31	45	40	22	56
3/4" (DN20)	PWR9440970	0.74	58	88.1	28	58	37	54	48	26	67
1" (DN25)	PWR9440981	1.02	68	102	33	66	44	63	56	32	79
1 1/4" (DN32)	PWR9440992	1.87	96	138	48	89	50	73	65	35	96
1 1/2" (DN40)	PWR9441003	2.32	97	148	48	99	59	86	75	38	105
2" (DN50)	PWR9441014	3.33	101	164	48	111	35	106	92	45	129

PP4426 double check valve PN10  
(2 x press)



specifications

- maximum pressure 10 bar
- operating temperature 0 to 65°C (short period 90°C)
- EN13959:2004 type ED
- spring assisted closure
- works in all orientations
- highly effective backflow prevention

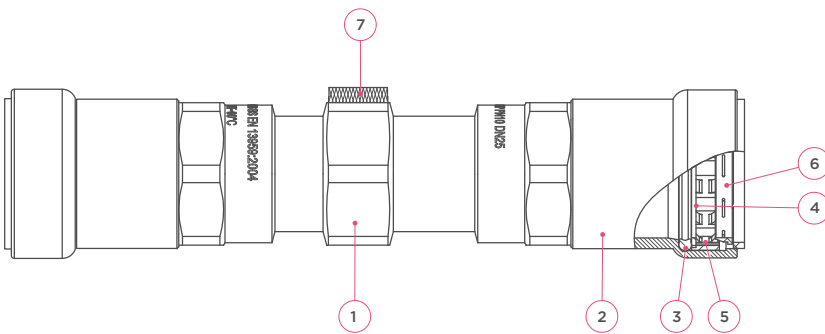

nr	part	material
1	body	DZR brass
2	press end	carbon steel zinc nickel plated
3	o-ring	EPDM
4	spacer ring	stainless steel
5	grab ring	stainless steel
6	Visu-Control® ring	polypropylene
7	vent	DZR brass

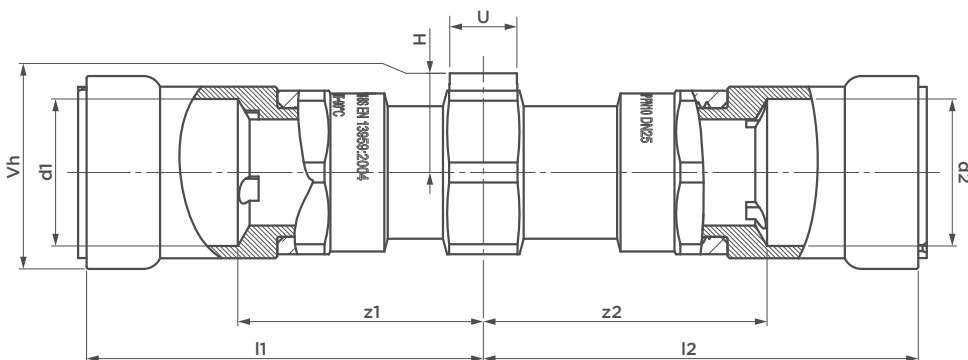

dimension	article no.	weight [kg]	l1	z1	l2	z2	U	H	Vh
1/2" (DN15)	PWR9440301	0.31	75	47	81	53	16	17	33
3/4" (DN20)	PWR9440310	0.46	82	52	90	59	16	20	39
1" (DN25)	PWR9440321	0.76	97	61	99	64	16	24	46
1 1/4" (DN32)	PWR9440332	1.17	121	73	127	78	16	28	56
1 1/2" (DN40)	PWR9440343	1.57	137	80	138	80	16	31	62
2" (DN50)	PWR9440354	2.50	163	109	165	111	16	37	74

PP1060A swing check valve PN16  
(2 x press)

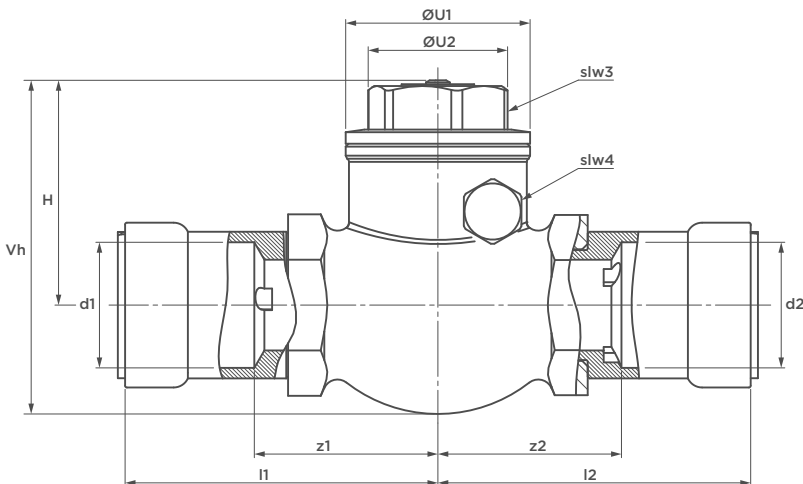
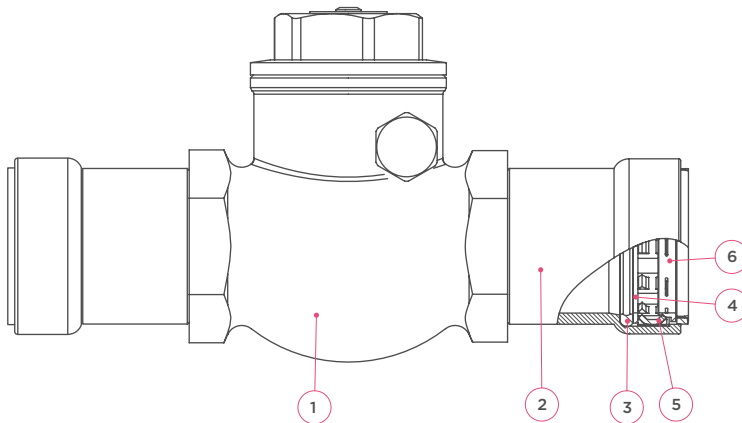

specifications

- maximum pressure 16 bar
- operating temperature 0 to 65°C
- bronze metal seated check valve
- horizontal and vertical fixing, indicated by flow directional arrow

nr.	part	material
1	body	gunmetal
2	press end	carbon steel zinc nickel plated
3	o-ring	EPDM
4	spacer ring	stainless steel
5	grab ring	stainless steel
6	Visu-Control® ring	polypropylene

dimension	article no.	flow (l/s)	Kv [m²/h]
1/2" (DN15)	9440244	0.04	1.80
		0.10	3.70
		1.02	5.10
		0.04	5.70
3/4" (DN20)	9440255	0.04	2.70
		0.10	5.50
		0.40	13.60
1" (DN25)	9440266	1.00	15.30
		0.01	7.70
		0.20	13.90
1 1/4" (DN32)	9440277	0.30	18.40
		1.00	25.30
		0.20	15.00
1 1/2" (DN40)	9440288	0.30	26.60
		0.40	25.30
		1.00	32.60
2" (DN50)	9440299	0.40	30.30
		0.60	40.20
		0.80	48.50
		3.00	54.40
2" (DN50)	9440299	0.60	42.00
		0.80	54.00
		1.50	86.20
		4.00	98.00

flow rate

dimension	article no.	weight [kg]	Kv [m²/h]	l/s	l1	z1	l2	z2	U1	U2	H	slw3	slw4	Vh
1/2" (DN15)	PWR9440244	0.555	5.7	0.4	69	41	69	41	40	29	46	26	13	68
3/4" (DN20)	PWR9440255	0.835	15.3	1.0	78	48	78	48	48	35	54	31	14	81
1" (DN25)	PWR9440266	1.208	25.3	1.0	86	51	86	51	51	40	62	35	16	92
1 1/4" (DN32)	PWR9440277	1.837	32.6	1.0	107	59	107	59	57	43	68	38	16	103
1 1/2" (DN40)	PWR9440288	2.357	54.4	3.0	116	68	116	68	65	50	77	43	16	120
2" (DN50)	PWR9440299	3.551	98.0	4.0	129	76	129	76	85	58	93	51	18	143



PP4 pressure reducing valve PN16  
(2 x press)



specifications

- maximum pressure 16 bar
- operating temperature -10 to 80°C
- allows high system pressures to be adjusted
- protects downstream equipment

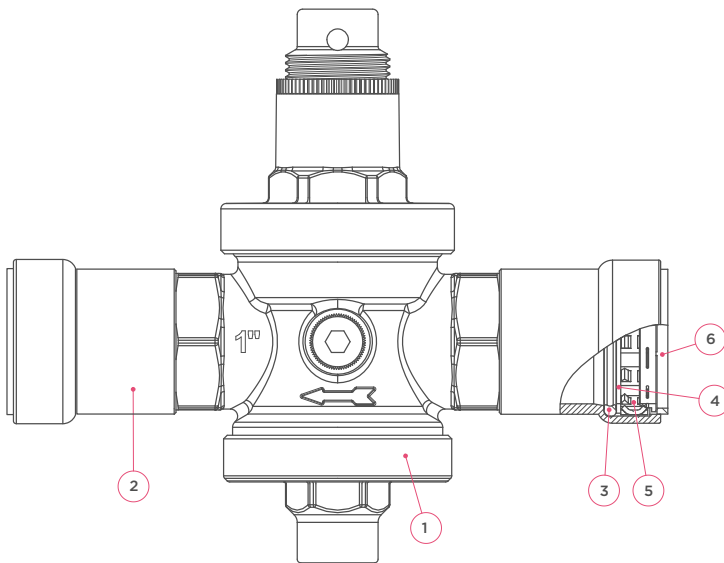

nr.	part	material
1	body	DZR brass
2	press end	carbon steel zinc nickel plated
3	o-ring	EPDM
4	spacer ring	stainless steel
5	grab ring	stainless steel
6	Visu-Control® ring	polypropylene

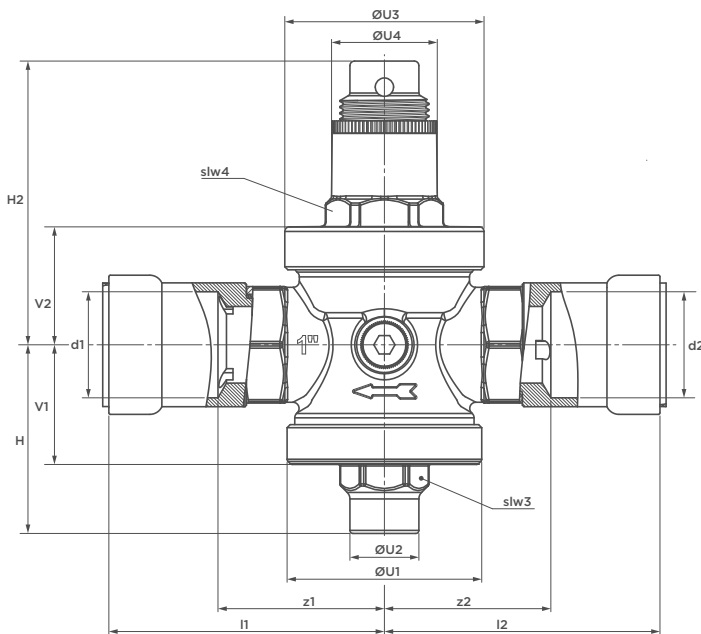

dimension	article no.	weight [kg]	l1/l2	z1/z2	U1	U2	U3	U4	H	H2	slw3	slw4	V1	V2
1/2" (DN15)	PWR9441025	0.87	77	49	52	20	50	29	45	81	24	-	33	32
3/4" (DN20)	PWR9441036	1.34	86	56	60	22	60	35	55	92	26	35	33	36
1" (DN25)	PWR9441047	1.67	90	55	64	23	65	35	62	93	26	35	39	39
1 1/4" (DN32)	PWR9441058	2.85	118	70	60	23	72	43	74	144	26	50	51	56
1 1/2" (DN40)	PRW9441069	3.14	125	76	60	23	72	43	74	143	26	50	51	55
2" (DN50)	PWR9441071	4.46	136	82	70	43	72	43	84	152	38	50	60	64



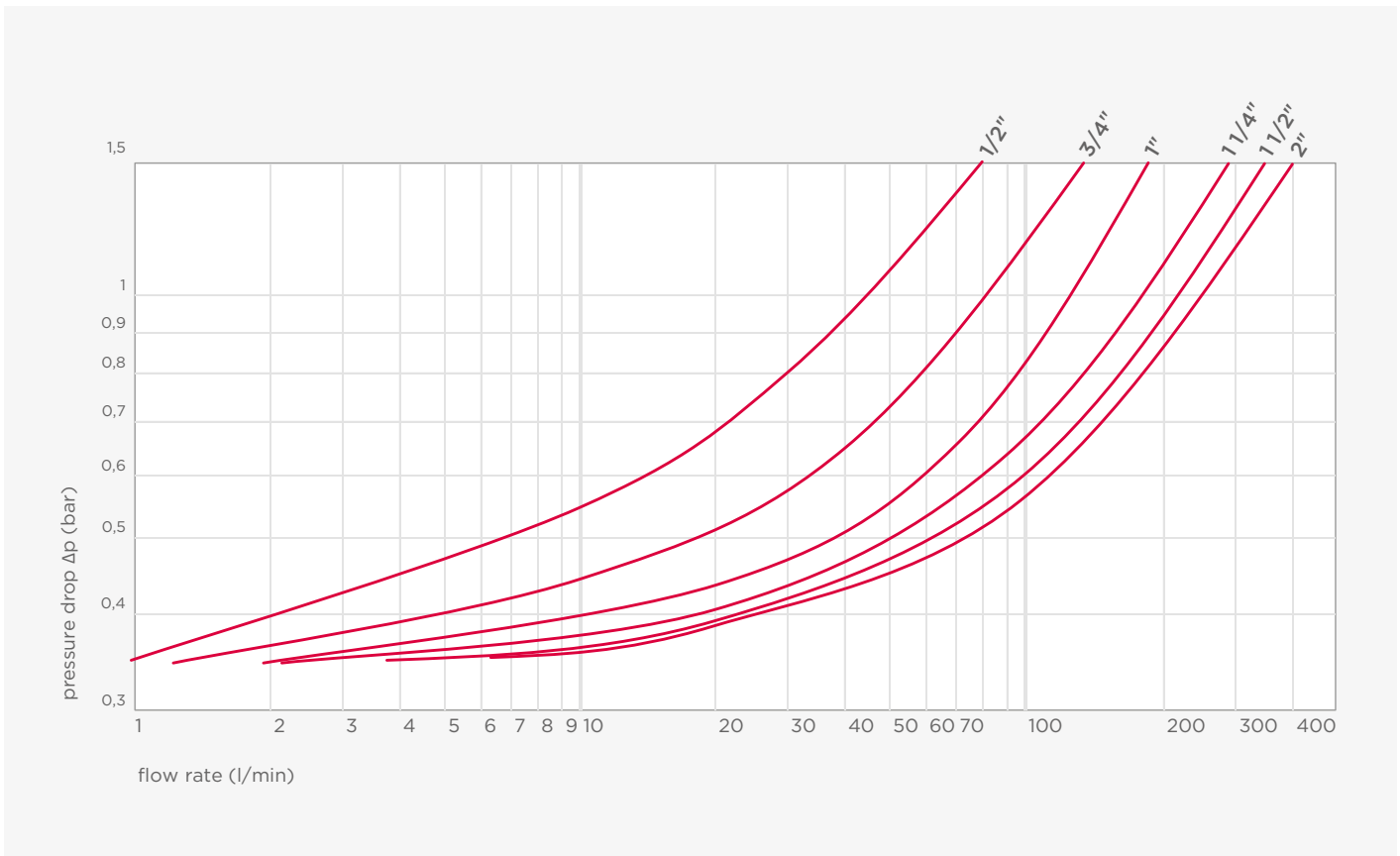

**5A2003 pressure gauge**  
(for PP4)



art. no.	description	weight [kg]
5A2003	pressure gauge	0,05





VSH PowerPress®  
tools and  
accessories

P6100 press tools Novopress



version	dimension	article no.
ACO203BT + battery + charger 220V + case	1/2" - 2"	6360079

P6101 press jaws and slings Novopress



version	dimension	article no.
PB2 ECOTEC jaw - DW	1/2"	6360002
PB2 ECOTEC jaw - DW	3/4"	6360013
PB2 ECOTEC jaw - DW	1"	6360024
ZB203 adapter	1" - 2"	6580145
snap-on sling - DW	1 1/4"	6360035
snap-on sling - DW	1 1/2"	6360046
snap-on sling - DW	2"	6360057
set: case + snap-on slings	1 1/4" + 1 1/2" - 2" + ZB203	6360090
set: jaws 1/2" - 1" + case	1/2" - 1"	6360167
set: jaws and slings 1/2" - 2" + ZB203 adapter + case	1/2" - 2"	6360178

P6102 case



version	dimension	article no.
case jaws + snap-on sling + adapter	1/2" - 2"	6360145

P6002 battery + charger



version	article no.
battery ACO203 1,5 Ah 18V	6340136
battery ACO203 3,0 Ah 18V	6340147
charger ACO203	6340125

## P6103 insertion depth marker



version	dimension	article no.
insertion depth marker for VSH PowerPress®	1/2" - 2"	PWR9401744







**disclaimer:**

*the technical data are non-binding and do not reflect the warranted characteristics of the products. They are subject to change. Please consult our General Terms and Conditions. Additional information is available upon request. It is the designer's responsibility to select products suitable for the intended purpose and to ensure that pressure ratings and performance data are not exceeded. The installation instructions should always be read and followed. The system must always be depressurized and drained before any components, whether defective or otherwise, are removed, modified or corrected.*

## more information?

---

more and comprehensive information about VSH PowerPress can be found at: [www.vsh.eu/powerpress](http://www.vsh.eu/powerpress)

for a complete and up-to-date product range and our additional services, visit: [www.vsh.eu](http://www.vsh.eu)

would you like to make an appointment to meet an account manager in your region or receive phone advice and support from one of our experts? Please contact:

<b>VSH Customer Service The Netherlands</b>	+31 (0)35 68 84 330
<b>VSH Customer Service Belgium</b>	0800 29320
<b>VSH Customer Service Luxembourg</b>	800 80956

available Monday to Friday, 8 am to 5 pm.  
[info@vsh.nl](mailto:info@vsh.nl).

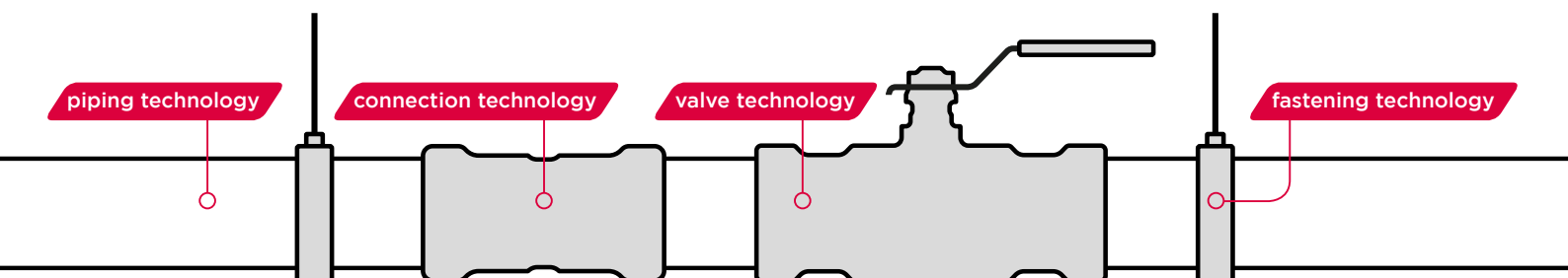

### VSH Fittings B.V.

Oude Amersfoortseweg 99 / 1212 AA Hilversum  
P.O. box 498 / 1200 AL Hilversum  
The Netherlands  
[www.vsh.eu](http://www.vsh.eu)